

Pinger Receiver Self-contained ROV Held Operating Manual

The 2405 is a standalone, battery powered, acoustic receiver system which can be used by an ROV for tracking and locating underwater acoustic pingers.



Collaborate • Innovate • Succeed



**CHALLENGE
ACCEPTED**

Royal Mechanical Group Pty Ltd

£ 61 (0) 452 506 896

Sales@royalmechgroup.com

www.royalmechgroup.com

Online Electronics Limited

+ 44 (0) 1224 714714

OEL-Sales@ik-worldwide.com

online-electronics.com

2405_5001

Rev	Date	By	Summary of change
A00	11/08/17	BG	CR00485: Was 2405 ROV ACOUSTIC RECEIVER MANUAL RevA12. CR00380: Address change. CR00499: Front cover update.
A01	06/10/17	BG	CR00499: Cover page update
A02	20/03/20	TL	CR00871: Email address, images and logos updated
A03	02/10/20	BG	CR00947; New front page

COMMENTS:

CONTENTS

Page

- 1. GENERAL DESCRIPTION 3
- 2. SPECIFICATIONS 4
- 3. OPERATION 5
 - 3.1. SELF TEST 6
 - 3.2. FUNCTION TEST 6
 - 3.3. TURNING ON..... 7
 - 3.4. OPERATING SCREEN 8
 - 3.5. SINGLE BUTTON MENU INTERFACE..... 9
 - 3.5.1. EXIT..... 9
 - 3.5.2. MANUAL MODE / AGC MODE 9
 - 3.5.3. SET TIME / DATE 9
 - 3.5.4. LEDS ON / LEDS OFF..... 10
 - 3.5.5. CONFIGURE 10
 - 3.5.6. SHUTDOWN 10
- 4. MAINTENANCE 11
 - 4.1. BATTERY REPLACEMENT 11
 - 4.2. 2405 O-RING REPLACEMENT..... 12
 - 4.3. ROUTINE MAINTENANCE AND STORAGE 12
- 5. DISPOSAL OF UNIT 13
- 6. WARRANTY 13

1. GENERAL DESCRIPTION

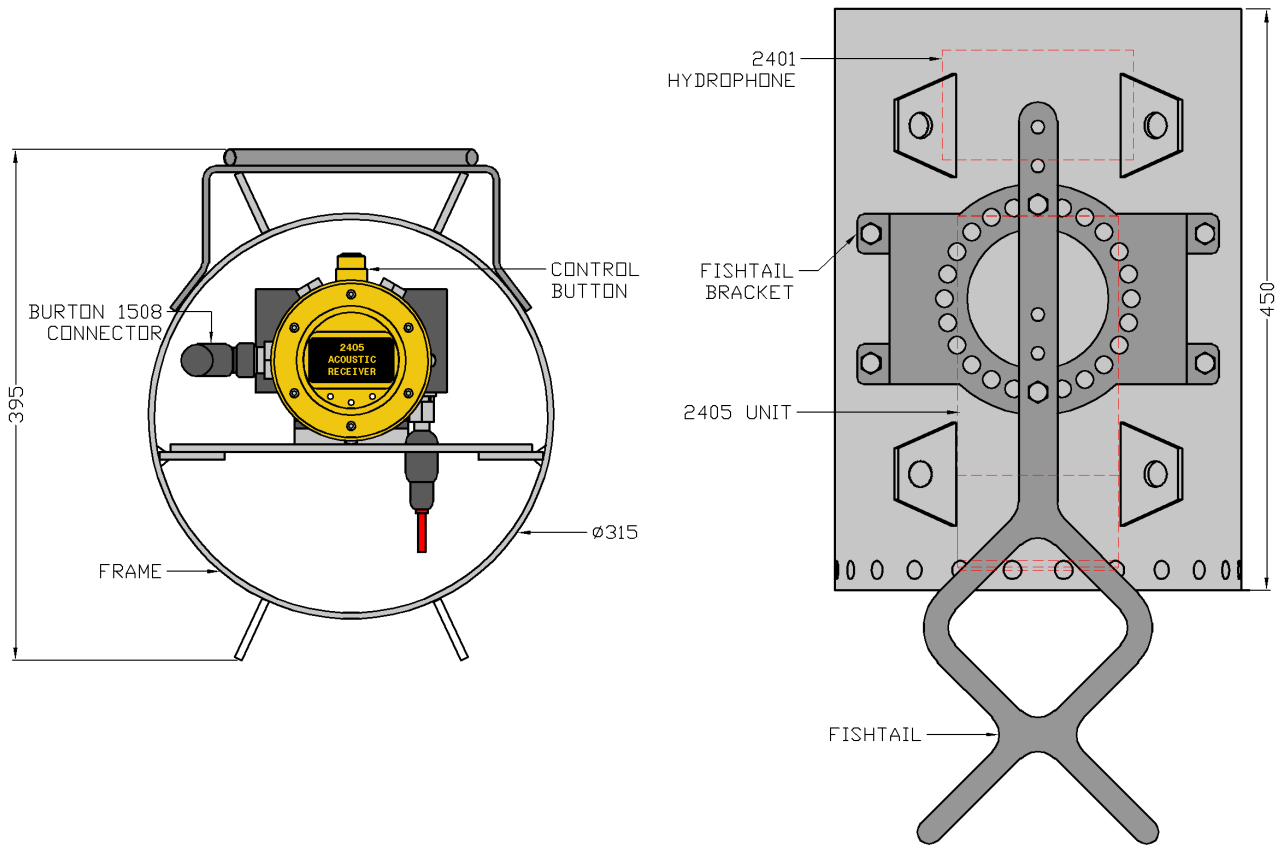

The 2405 Acoustic Receiver system is a standalone, battery powered, acoustic receiver system, tuneable to all frequencies between 8 kHz and 50 kHz which can be used by an ROV for tracking and locating underwater acoustic transmitters. The system consists of a 2405 unit and 2401 directional hydrophone.

Acoustic signals are displayed as they are received by the 2405 unit on a 2.7" graphical display and three high brightness LEDs positioned below the display. The 2405 system requires no interface other than an ROV camera to observe the received signals on the display. The user can turn the unit ON and OFF as well as modify several settings using a single control button and intuitive menu system on the 2405 unit.

The directional sensitivity of the 2401 hydrophone allows the operator to locate acoustic transmitters by observing the signal level received and the relative orientation of the 2401 hydrophone.

2. SPECIFICATIONS

Battery life at 5°C	130 hours
Battery type	10.5V Alkaline pack BATT-11210
Operating temperature range.....	-2°C to +35°C
Storage temperature range.....	-20°C to +50°C
Frame material.....	ALUMINIUM
Fishtail material	316 STAINLESS STEEL
Fishtail bracket material	316 STAINLESS STEEL
2405 Housing material	ALLOY BRONZE CA104 EN 12163
2405 Endcap material	ALLOY BRONZE CA104 EN 12163
2405 Bleedscrew material.....	ALLOY BRONZE CA104 EN 12163
2405 Window material	ACRYLIC
2405 Endcap O-rings	2x BS 50-243 NBR70 with 2x 250-243 PTFE BURs
2405 Window O-rings	1x BS 50-236 NBR70 / 1x BS 50-237 NBR70
2405 Bleedscrew O-ring	1x BS 50-008 NBR70
DGO Connector O-ring	1x BS 50-013 NBR70
System Weight in air.....	28kg

3. OPERATION

As with all acoustic systems, the ambient acoustic noise existing in the environment will have a significant impact on the performance of the 2405 system. Some of the most common sources of ambient acoustic noise are vessel engines, water turbulence and rough weather.

Also be aware that there may be nearby acoustic transmitters unexpectedly transmitting at (or close to) the frequency of interest. These should be disabled if possible. For example any acoustic beacons on the ROV must be disabled and any support vessels with dynamic positioning systems should be disabled or configured to work outside of the frequency of interest if possible.

The typical procedure for detecting an acoustic transmitter is given below. This procedure assumes the operator knows the expected frequency and pulse rate of the acoustic transmitter being searched for.

1. Before each deployment visually inspect all system components to ensure that they are secure and undamaged. Pay particular attention to the cable and connectors.
2. Before each deployment ensure that all tests described in section 3.1 SELF TEST and section 3.2 FUNCTION TEST are repeated.
3. Before deployment ensure the fishtail is positioned suitably, it can be positioned in several different positions on the fishtail bracket as required.
4. Use the control button to select the expected frequency of the acoustic transmitter.
5. It is recommended that AGC gain is selected as per section 3.5.2 MANUAL MODE / AGC MODE.
6. Select a timebase which will display approximately 5 pulses at the expected repetition rate on the screen as per section 3.4 OPERATING SCREEN.
7. Ensure the unit is turned on as per section 3.3 TURNING ON and the battery meter shows more than 50% capacity remaining. If less than 50% is indicated then change the batteries as per section 4.1 BATTERY REPLACEMENT.
8. Point the active face of the 2401 hydrophone towards the expected location of the acoustic transmitter. The active face of the 2401 points out of the tubular frame in the opposite direction to the 2405 display.
9. Very slowly scan in different directions while observing the signal received and the AGC value to try and determine which direction gives the strongest and clearest signal. Move in this direction to get as close as possible to the transmitter.
10. Confirm that the FREQUENCY and pulse rate of the acoustic signal are as expected. Be aware that there may be other acoustic transmitters in the environment (such as ROV beacons or dynamic positioning beacons). These sources should be disabled if possible otherwise it should be possible to identify the signal of interest by carefully examining frequency and pulse rate.

3.1. SELF TEST

1. Turn the 2405 ON as described in section 3.3 TURNING ON.

2. Put the 2405 into TEST MODE as per section 3.4 OPERATING SCREEN.

3. On entry to TEST MODE the unit sets the receiver frequency to 30kHz, timebase to 5 seconds, and gain to AGC003.



4. The unit then begins generating an internal 30kHz test signal with a repetition rate of 1 second at the 2401 input.

5. Because AGC gain is initially set to 003 (minimum setting) no signal will be seen however the unit should detect this and start increasing the AGC gain until the pulses are approximately $\frac{3}{4}$ of the way up the screen. This should take approximately 30 seconds. The final AGC value should be over AGC70.

6. Notice that because the timebase is 5 seconds and the internal test ping repeats every 1 second that 5 evenly spaced pulses should be visible on the screen and a 1SEC repetition rate should also be detected at the bottom right hand side of the screen as shown.

7. The 2405 will remain in TEST MODE for 4 minutes or until the operator manually enters PINGER MODE.

8. Note that any pre-configured frequency, timebase and gain settings entered prior to entering TEST MODE will be saved.

3.2. FUNCTION TEST

1. Turn the 2405 ON as described in section 3.3 TURNING ON.

2. Ensure the 2405 is in PINGER MODE with AGC gain as per section 3.4 OPERATING SCREEN.

3. Activate a test transmitter of known frequency and repetition rate within range of the 2401 hydrophone. A range of approximately 5cm should be used if in air.

4. Set the frequency of the 2405 to the transmitter frequency.

5. Confirm that the AGC gain adjusts until the pulses are approximately $\frac{3}{4}$ up the screen. Adjust the timebase if necessary until approximately 5 pulses are present on the screen. Confirm that the timebase and number of pulses on the screen reflect the expected repetition rate. The LEDs should illuminate during each pulse and the correct repetition rate should be displayed on the bottom right of the screen.

6. If a test transmitter is not available then a crude signal can be generated by very gently tapping the active face of the 2401 hydrophone with a finger. The signal should be visible on the screen with the frequency of the 2405 set to 9kHz.

7. Turn off any test transmitters and remove any local sources of obvious noise and/or vibration. Because no signal is present the AGC should increase to AGC255. The noise level displayed should be less than $\frac{1}{4}$ up the screen.

3.3. TURNING ON

There is a hole on top of the frame that allows access to the control button of the 2405 module, to turn the unit on simply press and hold the control button until the COMPANY LOGO appears on the screen. This should take approximately 5 seconds.

The next screen shows the PRODUCT LOGO and firmware version at the bottom of the screen in vXX format. This screen will be displayed for 5 seconds as shown by the COUNTDOWN INDICATOR at the bottom left corner of the display.

When the COUNTDOWN INDICATOR reaches zero or the control button is pressed the next screen will appear.

The next screen shows the TIME & DATE, see section 3.5.3 SET TIME / DATE for more information.

The unit now completes an INTERNAL CHECK of functionality. On successful completion the unit will go to the OPERATING SCREEN. If the check fails then an error message will be displayed before the unit goes to the OPERATING SCREEN.

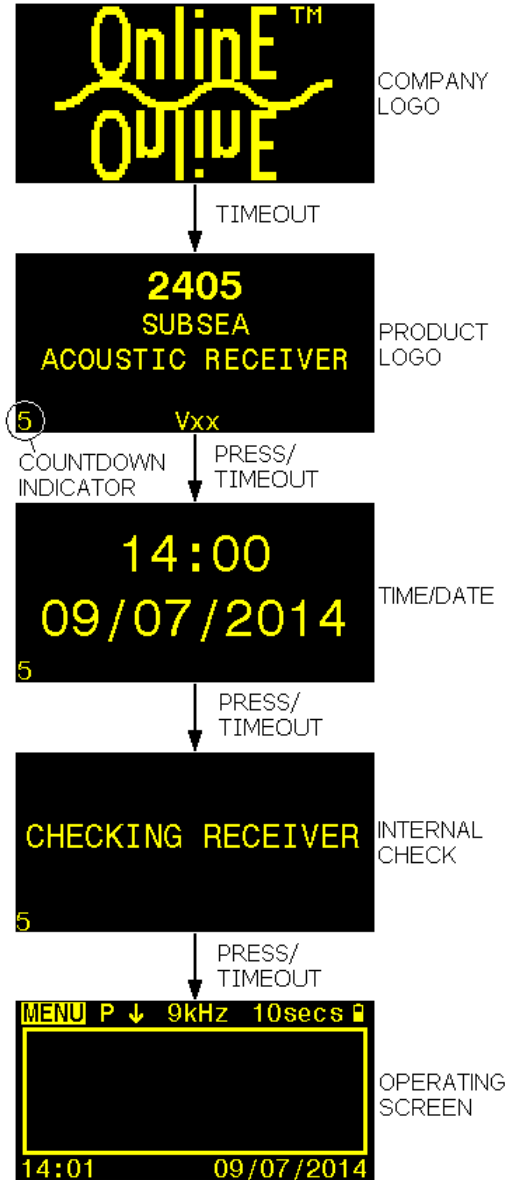

3.4. OPERATING SCREEN

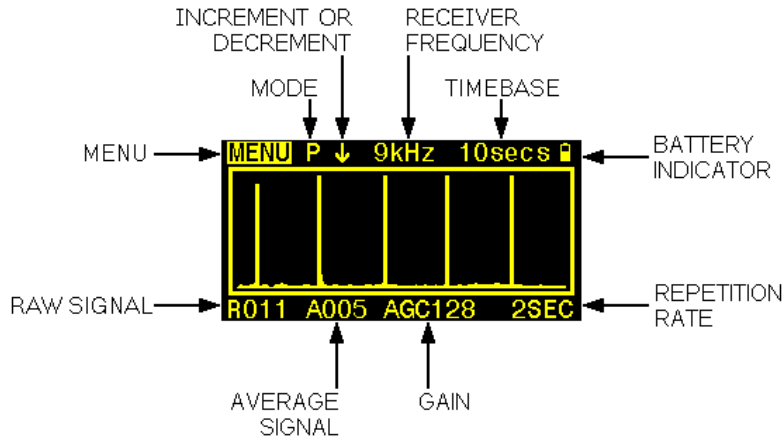

The figure above shows the operating screen with a typical 9kHz ping being received every 2 seconds. The operator can select and modify several items on this screen. Individual items are highlighted (MENU is shown highlighted here) by using long presses on the 2405 CONTROL BUTTON to move between items. Once the required item is highlighted a short press on the 2405 CONTROL BUTTON will select or modify the highlighted item. The screen shows the following items.

- MENU. Enters the menu system when selected. See section 3.5 SINGLE BUTTON MENU INTERFACE for more information.
- MODE. Toggles between (P)INGER MODE and (T)EST MODE if selected. PINGER MODE is the normal operational mode used when searching for acoustic transmitters. TEST MODE is used to confirm functionality of the unit as described in section 3.1 SELF TEST.
- INCREMENT OR DECREMENT. Toggles between incrementing (↑) or decrementing (↓) configurable items when selected.
- RECEIVER FREQUENCY. Allows the operator to configure the receiver frequency between 8kHz and 50kHz when selected.
- TIMEBASE. Allows the operator to set the timebase width of the screen between 3secs and 50secs when selected. As shown, if the timebase is set to 10 seconds and a pulse is received every 2 seconds then you would expect to see approximately 5 evenly spaced pulses on the screen.
- GAIN. If MANUAL gain is selected then this value will have format MAN### and the operator will be able to configure the gain between 003 and 255. If AGC (Automatic Gain Control) is selected then this value will have format AGC### and the gain will be adjusted automatically by the 2405. If AGC is selected then the gain cannot be configured manually.
- BATTERY INDICATOR. Gives an indication of the remaining battery capacity.
- REPETITION RATE. When a distinct pulse is detected then the time since the last distinct pulse is displayed in ##SEC format.
- AVERAGE SIGNAL. This value shows an average of the received signals on the screen in A### format. This gives an indication of the noise level in the system with a lower number meaning a quieter (better) environment.
- RAW SIGNAL. Shows the instantaneous level of signal in R### format. When a pulse appears this value will peak, the stronger the pulse, the higher the number.

3.5. SINGLE BUTTON MENU INTERFACE

The MENU system can be entered from the OPERATING SCREEN as described in section 3.4 OPERATING SCREEN.

While in the MENU system, every time the user presses the control button the CURSOR will move down one line and the COUNTDOWN INDICATOR will be reset to 5.

Once the CURSOR is pointing at the desired item the user simply allows the COUNTDOWN INDICATOR to reach 0 and the selected item will be executed. This simple behaviour is used throughout the menu interface to modify settings and interact with the 2405 unit.

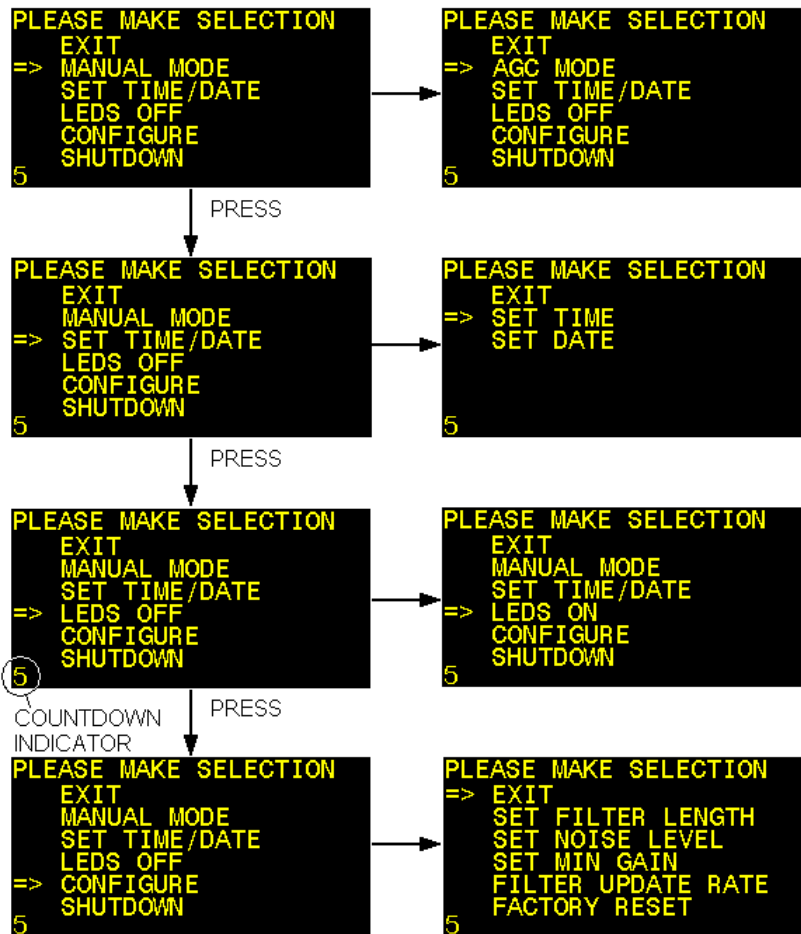

3.5.1. EXIT

The first item on every page of the menu system is EXIT. If no other selection is made then EXIT is selected by default and the 2405 will exit the menu system and return to the OPERATING SCREEN.

3.5.2. MANUAL MODE / AGC MODE

This item toggles between AGC MODE (Automatic Gain Control) and MANUAL MODE gain control. It is recommended that AGC mode is used during most deployments although in environments where the background noise level is unstable it can be advantageous to use MANUAL MODE to prevent the AGC constantly changing gain in response to variations in background noise levels. See section 3.4 OPERATING SCREEN.

3.5.3. SET TIME / DATE

This item allows the time and date to be adjusted. Ensure that a valid time is entered in 24hour, HH:MM:SS format and a valid date in DD/MM/YY format.

The digit to be edited is indicated by '^' below the digit. Press the push button momentarily until the required value is displayed. Once the correct value for the digit is displayed allow the countdown timer to expire and the selection arrows will advance to the next digit.

While setting the seconds field the control button can be held down to freeze the current time to help synchronise with a reference time.

3.5.4. LEDS ON / LEDS OFF

This item will toggle the LEDs ON or OFF. If the LEDs are ON then they will flash on receipt of a distinct pulse otherwise they will remain OFF.

3.5.5. CONFIGURE

This item brings up a second menu which has numerous system level variables which should not be modified. Any modifications made in the CONFIGURE menu should only be done in conjunction with instruction from Online Electronics personnel. The FACTORY RESET OPTION can be selected at any time to ensure the unit is using the factory default settings which are adequate for the majority of situations.

3.5.6. SHUTDOWN

This item switches the unit OFF. The unit is fitted with non-volatile memory which will remember all settings made via the menu system next time the unit is switched ON. It is imperative that the 2405 unit is turned OFF using this command rather than simply disconnecting the battery so any memory storage processes are allowed to terminate prior to turning OFF.

4. MAINTENANCE

NOTE 1 - ALWAYS LOOSEN THE BLEEDSCREW TO RELIEVE ANY INTERNAL PRESSURE PRIOR TO OPENING.

NOTE 2 - DO NOT EXPOSE TO AGGRESSIVE SOLVENTS OR CHEMICALS WHICH COULD BE HARMFUL TO THE HOUSING, NITRILE RUBBER O-RINGS, THE ACRYLIC WINDOW, OR CONNECTORS.

NOTE 3 - OPENING OF THE UNIT SHOULD ONLY TAKE PLACE IN A CLEAN, DRY, LABORATORY ENVIRONMENT.

NOTE 4 - TO PREVENT THE FORMATION OF CONDENSATION WITHIN THE UNIT ALLOW THE UNIT TO STABILISE WITHIN THE LABORATORY ENVIRONMENT FOR A MINIMUM OF 6 HOURS PRIOR TO OPENING.

4.1. BATTERY REPLACEMENT

1. Observe how the cable is routed between the 2405 unit and 2401 hydrophone before carefully loosening and detaching the cable connections at the 2405 and 2401 and feeding the cable through the forward hole in the mounting plate so that the mounting plate can be removed without damaging the cable.
2. Remove the 4x M8 CAP screws that secure the mounting plate to the frame and remove the mounting plate with 2405 unit and 2401 hydrophone attached being careful not to damage the cable.
3. Remove the 2x M10 bolts which hold the 2405 unit onto the mounting plate.

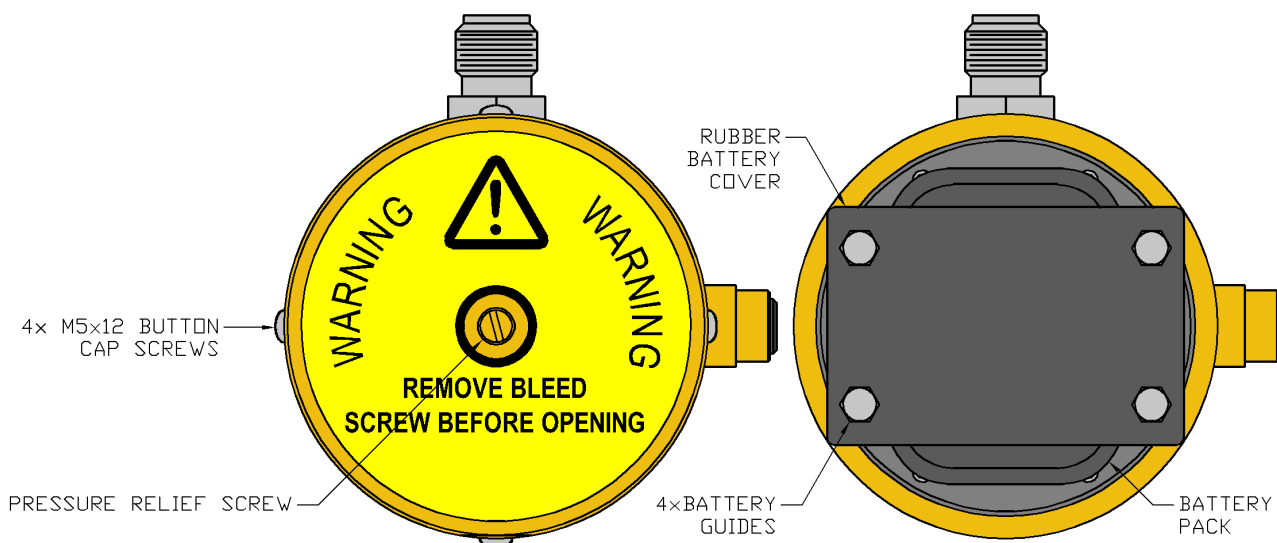

4. Loosen the bleedscrew on the rear of the 2405 to relieve any internal pressure.
5. Remove the 4x M5 BUTTON CAP screws around the perimeter of the housing.
6. Carefully remove the housing from the endcap to reveal the battery pack as shown above. Ensure that the O-ring seals are protected from damage and contamination while the unit is open.
7. Observe how the battery is installed and how the wires are routed before proceeding.

8. Ensure that the 2405 is turned OFF before disconnecting the battery. The rubber battery cover is simply pulled over the battery guides. Replace the battery and ensure all wires are installed neatly and protected from accidental damage.
9. Examine the 2405 O-ring seals for any signs of damage or contamination. Replace if necessary.
10. Reassemble the system following the above instructions in reverse. Remember to tighten the bleedscrew on the rear of the 2405 once the housing has been closed.
11. Do not use spanners to tighten any of the connector collars otherwise damage may occur. The collars should be hand tightened only. Grease the connectors with a suitable grease if necessary.
12. Note that the DGO connectors at the 2401 hydrophone include an internal O-ring and BUR (Back Up Ring) positioned as shown. Look into each half of the connector and confirm that the O-ring and BUR are in position and are undamaged. If these seals are missing or damaged then the system may malfunction when deployed subsea.

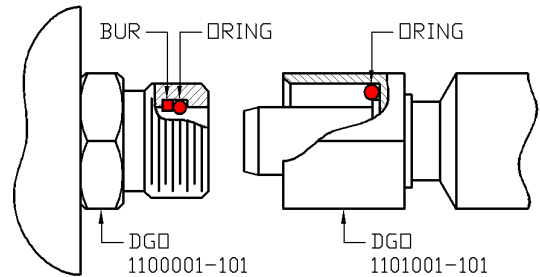

4.2. 2405 O-RING REPLACEMENT

The 2405 uses the following O-rings:

- 1x 50-008 groove in piston bleedscrew O-ring.
- 2x 50-243 groove in piston endcap O-rings with 2x 250-243 PTFE Back Up Rings.
- 1x 50-236 groove in flange window O-ring / 1x 50-237 groove in piston window O-ring.

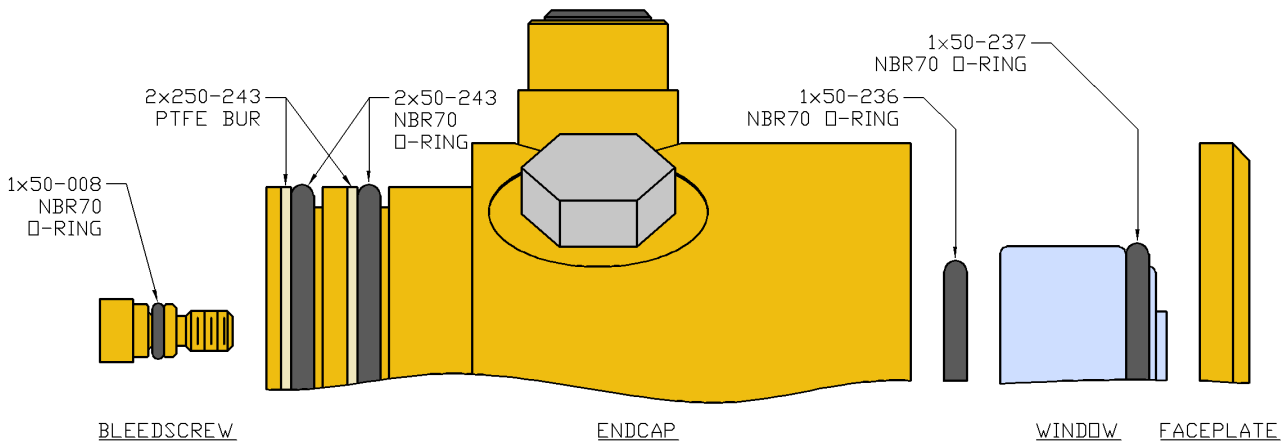

4.3. ROUTINE MAINTENANCE AND STORAGE

All Online Electronics Ltd products are designed to require minimum maintenance. The housing should be cleaned using fresh water and cleaning agents as necessary. Do not use chemicals which could be damaging to the housing, the nitrile rubber O-rings, the acrylic window, or any connectors.

If the unit is to be placed in storage for a long period of time ensure the unit has been cleaned and disconnect the main battery.

5. DISPOSAL OF UNIT

Online Electronics Ltd takes its responsibilities under the WEEE Regulations extremely seriously and has taken steps to be compliant in line with our corporate and social responsibilities. In the UK, OEL has joined a registered compliance scheme WeeeCare (registration number **WEE/MP3538PZ/SCH**).

Electrical and electronic equipment should never be disposed of with general waste but must be separately collected for the proper treatment and recovery.

The crossed out bin symbol, placed on the product, reminds you of the need to dispose of it correctly at the end of its life.

When buying a new product you will have the possibility to return, free of charge, another end of life product of equivalent type that has fulfilled the same functions as the supplied equipment. These items may be deposited at:

Online Electronics Ltd
Online House
Woodburn Road
Blackburn Business Park
Blackburn
Aberdeen
AB21 0PS
UK

Alternatively, to arrange a collection of any waste electrical equipment, obligated to OEL please telephone WeeeCare on **0844 800 2004**.

6. WARRANTY

Online products are guaranteed for one year from the date of purchase. Goods should be returned transportation prepaid to Online Electronics Limited.

There is no charge for parts or labour should any product require repair due to a manufacturing deficiency during the guarantee period.

In the event of a manufacturing deficiency the inward transportation costs will be repaid to the client.