

Online ENGINE

NON-INTRUSIVE PIG SIGNALLER MAGNETIC TOPSIDE OPERATING MANUAL

The 4003 MAGSIG® is a fully ATEX, IECEx and CSA/cUL certified, non-intrusive pig signaller which quickly and accurately detects, signals and logs the passage of magnetic pigs at critical points along a pipeline both on land and offshore

Online Electronics Ltd
Online House
Blackburn Business Park
Woodburn Road, Blackburn
Aberdeen
AB21 0PS
UK
+44 (0)1224 714 714
www.online-electronics.com
sales@online-electronics.com

Royal Mechanical Group Pty Ltd
Level 14, 197 St. Georges Tce,
Perth, WA 6000
Australia
+61 (0) 452 506 896
www.royalmechgroup.com
Sales@royalmechgroup.com

ROYAL
OIL & GAS



Collaborate • Innovate • Succeed An IK Group Company

CONTENTS

Page

1.	GENERAL DESCRIPTION	5
2.	SPECIFICATIONS.....	6
2.1.	GENERAL	6
2.2.	STANDARD OUTPUTS:	6
3.	RULES FOR SAFE OPERATION	7
4.	OPERATION	8
4.1.	TURNING ON	8
4.2.	STABILISATION.....	9
4.3.	LISTENING	9
4.4.	DETECTION MODE	10
4.4.1.	PIG PASSED.....	10
4.4.2.	PIG DETECTION ONLY.....	10
4.4.3.	DETECTION DELAY.....	11
4.5.	SINGLE BUTTON MENU INTERFACE.....	12
4.5.1.	VIEW EVENTS	14
4.5.2.	COPY EVENTS TO SD CARD	14
4.5.3.	DELETE ALL EVENTS.....	14
4.5.4.	SHUTDOWN	14
4.5.5.	DATE	15
4.5.6.	TIME	15
4.5.7.	THRESHOLD.....	15
4.5.8.	POWER MODE	15
4.5.9.	STABILISATION DELAY	15
4.5.10.	DETECTION DELAY.....	15
4.5.11.	DETECTION METHOD.....	15
4.5.12.	AUTO POWER OFF.....	16
4.5.13.	RELAY LOGIC	16
4.5.14.	SENSOR SELECT	16
4.5.15.	SENSOR OUTPUT	16
4.5.16.	LED FLASH	16
4.5.17.	BLUETOOTH.....	17
4.5.18.	INTERFACE	17
4.5.19.	RS485 BAUD RATE.....	17
4.5.20.	RS485 PARITY	17
4.5.21.	MODBUS ADDRESS	17
4.5.22.	SD LOG	17
4.5.23.	LANGUAGE	17
4.5.24.	RESET TO FACTORY SETTINGS.....	17
4.5.25.	EXIT MENU	18
4.6.	MODBUS RTU RS485 INTERFACE	18
4.6.1.	MODBUS REGISTER MAP	18
4.7.	EVENT LOGGING AND SD Card	20
4.7.1.	EVENT LOGGING.....	20
4.7.2.	SD CARD.....	20
4.8.	MOUNTING.....	21
4.8.1.	REMOTE SENSOR MOUNTING.....	21
4.9.	BATTERY REPLACEMENT	22
4.10.	EXTERNAL CONNECTIONS	23
4.10.1.	RELAY OUTPUT	24
4.10.2.	CURRENT LOOP OUTPUT	24
4.11.	INTERNAL HEATER	24
4.12.	RTC BACKUP.....	25
4.13.	RECOMMENDED MAGNET ARRANGEMENT	26
5.	BLUETOOTH INTEGRATION	27
5.1.	BLUETOOTH ENABLE	27
5.2.	BLUETOOTH CONNECTION	27
5.3.	DEVICE DISPLAY INFORMATION	29

5.3.1.	DEVICE CHANGEABLE FIELDS	29
5.3.2.	INDICATION ONLY	29
5.3.3.	LOGGED DATA:	29
6.	ROUTINE MAINTENANCE AND STORAGE	30
7.	DISPOSAL	30
8.	WARRANTY	30
9.	SAFETY INSTRUCTIONS	31

1. GENERAL DESCRIPTION

The OnlinE 4003 MAGSIG® is a robust, non-intrusive magnetic pig signaller which detects, signals, and logs the passage of magnetic pigs at critical points along a pipeline both on land and offshore. Events are signalled as they occur via an OLED dot matrix display and high brightness LEDs positioned around the perimeter of the display.

The unit logs the time and date of up to 100 events. Logged events can be viewed locally on the dot matrix display, transmitted remotely over several optional interfaces, or downloaded using a laptop or onto a SD card. The unit can also continuously log sensor data to SD card. The user can turn the unit ON and OFF as well as modify several settings using the single control button and intuitive menu system.

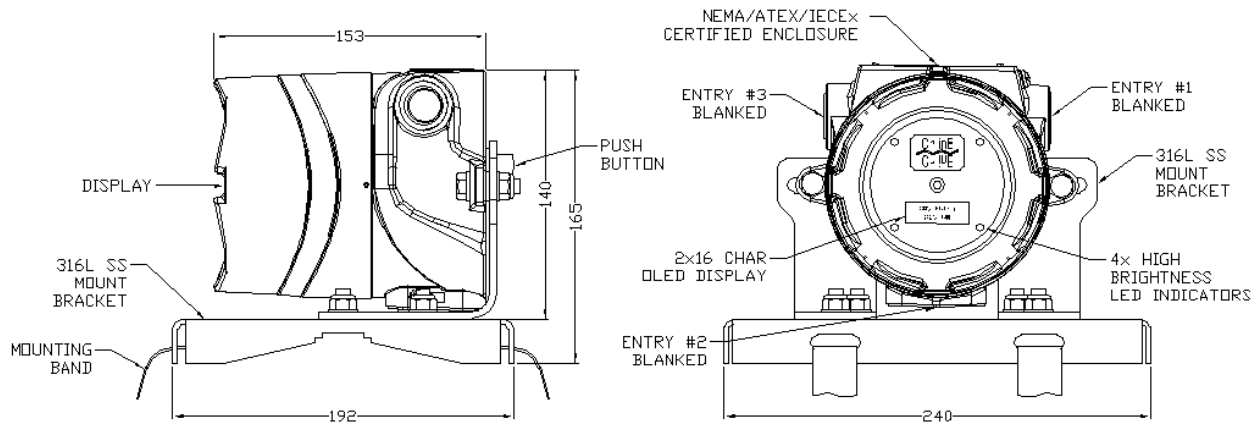

The unit can be quickly and easily attached to a pipeline using ratchet straps or steel banding. The unit is suitable for use on pipeline diameters up to 60" with wall thickness up to, and in excess, of 40mm (please contact Online Electronics Ltd when wall thickness exceeds 25mm). Detection speed ranges from 0.01 to 20 metres per second. Window of detection is typically 0.5m either side of the unit. The detection capabilities vary depending on the background magnetic noise, pig speed, pipeline diameter, wall thickness and the quality of magnets fitted. For optimum performance it is recommended that pigs are fitted with magnets as described in section 4.13 RECOMMENDED MAGNET ARRANGEMENT.

POWER OPTIONS: The unit can be powered from internal batteries or from an external +24VDC supply. Batteries can be fitted to provide backup power should the external supply fail. The unit uses either 4 off individual 'D' sized cells which can either all be Alkaline (DURACELL ID1300) OR NiMH (Annsman Max E – ATEX/IECEX only). The 4003 also caters for 2 off Lithium (SAFT LS33600) cells, this option being configured at manufacture.

ENTRY OPTIONS: The standard unit comes with 2 off ¾" NPT entries with blanking elements installed. There is room inside the unit to make electrical connections without the need for additional junction boxes or enclosures. Certified adaptors are generally available for other thread types.

REMOTE SENSOR OPTION: The 4003 sensor is available in its own metal housing and is connected to the main unit via solid or flexible conduit. A junction box provides 2 entries for external electrical and signal connections.

MATERIAL OPTIONS: The unit can be supplied with an epoxy coated Aluminium Alloy 6082-T6 or uncoated 316L Stainless Steel housing. Alternative coatings can be catered for.

TEMPERATURE RANGE OPTIONS: Ambient temperatures of -50°C can be accommodated by installing a heater within the electronics housing. Higher pipeline surface temperatures can be accommodated using a thermally insulated remote sensor.

2. SPECIFICATIONS

2.1. GENERAL

External supply	+21.6VDC to +26.4VDC, <1.0W
Loop powered current loop	8- 20mA
Temperature range using external supply (NO CELLS FITTED)-50°C to +85°C (-58 to +185°F)
Battery type.....	4x DURACELL ID1300 Alkaline cells
Battery type.....	4x Ansmann NiMh cells (ATEX/IECEX only)
Battery type.....	2x SAFT LS33600 Lithium cells
Battery life in LISTENING/LOW POWER MODE at +20°C.....	1 Year
Temperature range while cells installed	Refer to Section 9 SAFETY INSTRUCTIONS
Ingress Protection	IP66 / NEMA 4X
ATEX/IECEX code	Refer to Section 9 SAFETY INSTRUCTIONS
EC Type Examination Certificate Number.....	SIRA18ATEX1244X
IECEX Certificate Number	SIR 18.0059X
CSA/CSA-US	CSA18CA70166719
Weight in Aluminium	3.5kg (8lbs)
Weight in Stainless Steel	5.5kg (12lbs)

2.2. STANDARD OUTPUTS:

DPDT Relay Output (Volt Free Contacts)	2A @ 30VDC / 0.5A @ 125VAC
ISA TYPE II 2 wire Current Loop Output	<16mA (Listening)/>18mA(DETECTION)
MODBUS	RTU (RS485)
BLUETOOTH.....	Class 4 (BLE)

3. RULES FOR SAFE OPERATION

⚠ WARNING: The Special Conditions for Safe Use detailed in Section 9 SAFETY INSTRUCTIONS of this manual must be observed at all times.

⚠ WARNING: The purchaser of this equipment is responsible for the training and competence of operators and the manner in which it is used. This manual should be read through and understood before installation and commissioning so that the operator is familiar with the equipment. Contact Online Electronics Ltd immediately should any difficulty arise in the use of this equipment.

⚠ CAUTION: If the unit is to be placed in storage, always ensure that it is turned OFF and the batteries are removed and stored separately.

4. OPERATION

Familiarise yourself with the rules for safe operation of this equipment as described in Section 3 RULES FOR SAFE OPERATION.

The 4003 provides a 2x16 OLED dot matrix display at the front of the unit. A control button is located on the rear of the unit. Push the control button firmly and evenly to operate.

4.1. TURNING ON

If external power is available, the unit will turn on automatically when power is applied.

To turn the unit on when battery operated simply press and hold the control button until the COMPANY LOGO appears on the display and then release, this takes approximately 5 seconds.

The COMPANY LOGO will be displayed for 5 seconds after power is applied or the button is released as shown by the COUNTDOWN INDICATOR located at the lower left corner of the display.

The COMPANY LOGO and subsequent start up screens can be aborted by pressing the CONTROL BUTTON.

The next screen shows the PRODUCT LOGO and firmware version.

The next screen shows the current date and time. If the date and time has not been set or the RTC backup has expired, an error message will be displayed to indicate that the date and time require setting by the user.

The next screen shows the status of the AUTO POWER OFF feature. See section 4.5.12 AUTO POWER OFF for more information.

The next screen shows the detection method selected. Reference section 4.5.11 DETECTION METHOD.

The unit now enters STABILISATION. During STABILISATION the unit will not detect or log any magnetic events and the LEDs will flash every 5 seconds. The remaining STABILISATION time is displayed in HH:MM:SS format. When the STABILISATION time reaches zero or the CONTROL BUTTON is pressed, the unit will enter LISTENING MODE. See section 4.2 STABILISATION for more information.

While LISTENING, the screen will show the live DIFFERENCE flux reading and the current number of events logged along with the date and time of the most recent event. The LEDs will flash every 5 seconds. See section 4.3 LISTENING for more information.

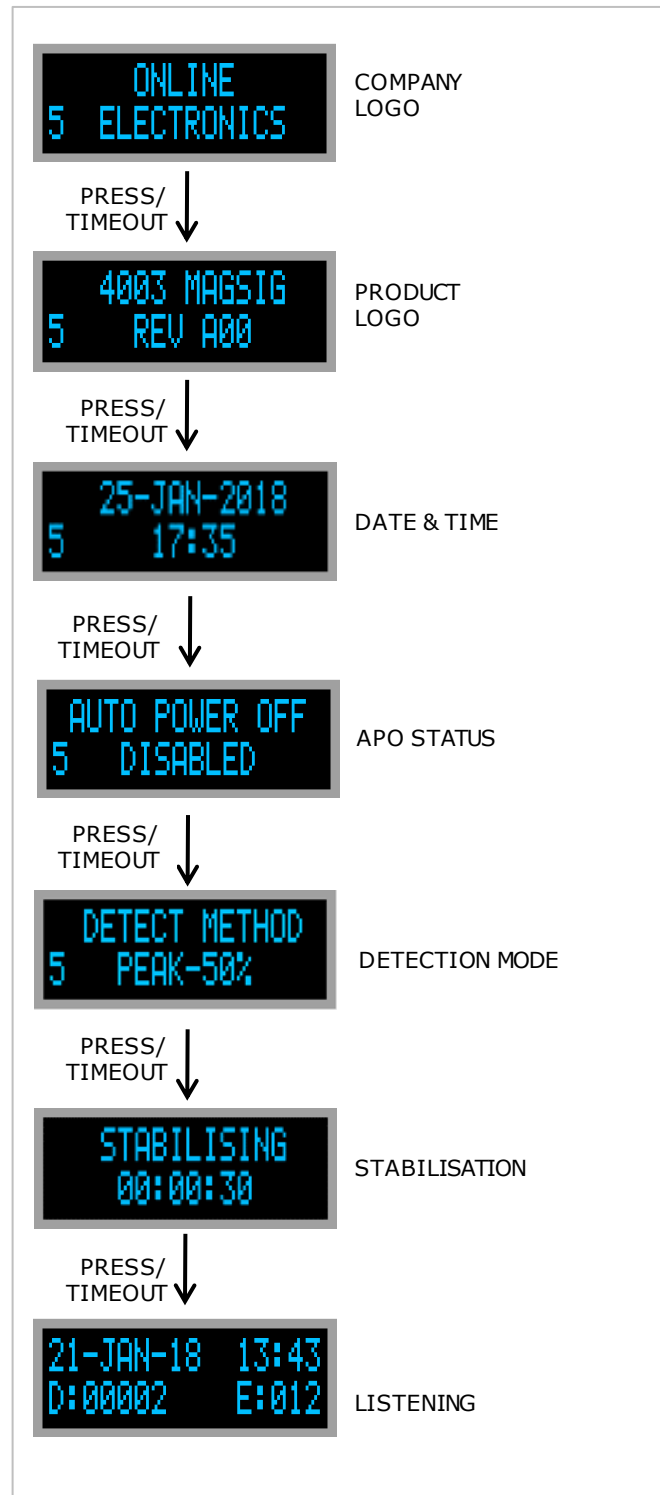

4.2. STABILISATION

The STABILISATION delay occurs at switch ON only. During the STABILISATION delay the unit will ignore all magnetic events. The LEDs will flash every 5 seconds and the relay and current loop outputs will be in the DETECTION state. The STABILISATION delay can be used during deployment to prevent any unwanted events from being logged due to movement of the unit in the earth's magnetic field and/or movement of nearby magnetic objects (such as vehicles).

The STABILISATION delay can be set to any value between 00:00:00 and 99:59:59 (in HH:MM:SS format) using the CONTROL BUTTON or via the serial link. During the STABILISATION delay a countdown timer is shown on the display, once this timer reaches 00:00:00 the unit will start LISTENING. The STABILISATION delay can be bypassed by pressing the CONTROL BUTTON at any point during STABILISATION.

Remember that the STABILISATION delay occurs at switch ON only. If changes are made to the STABILISATION delay setting then the unit should be turned OFF. The new STABILISATION delay will occur whenever the unit is next turned ON.

4.3. LISTENING

Immediately after STABILISATION the unit will display the LIVE DATA screen, similar to the screens shown opposite.

If 0 events have occurred, this screen will show E:00 with no date or time.

Once an event has occurred, this screen will show the most recent EVENT number and the date and time the event occurred. The example shown is EVENT #12 which occurred on 01/21/18 at 13:43 (in MM/DD/YY HH:MM format).

The live DIFFERENCE flux reading D:0002 is also displayed. In a magnetically quiet environment this number can be expected to flicker between 0000 and 0005. After displaying the LIVE DATA screen for 10 seconds the display will be switched off as shown opposite.

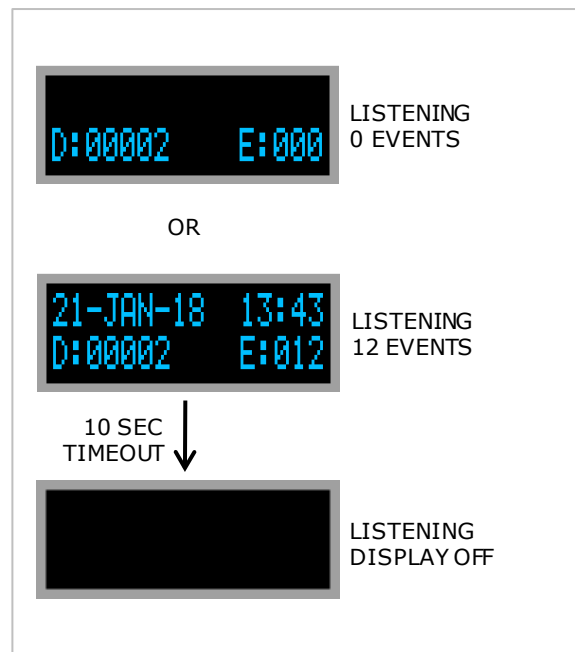

While LISTENING the LEDs around the display will flash every 5 seconds, if enabled, and the relay and current loop outputs will be in the LISTENING state. The unit continually takes RAW flux readings which are FILTERED and the DIFFERENCE between the RAW and FILTERED values calculated. If the DIFFERENCE exceeds the THRESHOLD setting, then the unit will enter DETECTION MODE where an event will be signalled if the detection criteria is met. The following events may interrupt the unit while in listening mode:

MAGNETIC EVENT – If a DIFFERENCE flux reading greater than the THRESHOLD value is detected while the unit is LISTENING, the unit will enter DETECTION MODE once the detection criteria has been met an EVENT will be signalled (discussed in section 4.4 DETECTION MODE).

CONTROL BUTTON – Holding the CONTROL BUTTON momentarily (< 1 second) will enable the LIVE DATA screen for 10 seconds. Holding the CONTROL BUTTON for > 3 seconds will enter the MENU interface which is described in section 4.5 SINGLE BUTTON MENU INTERFACE of this manual.

SERIAL COMMAND – If a serial command is received via the serial data link then it will be processed before the unit continues LISTENING.

4.4. DETECTION MODE

There are two DETECTION MODES. The default PIG PASS mode detects when the PIG has likely to have PASSED the signaller and DETECTION ONLY detects the presence of a pig but not necessarily that it has passed. The latter is useful when trying to determine when a PIG has been launched, where the pig is initially present, and the pig's movement will be away from the signaller – i.e. will not create a flux peak.

4.4.1. PIG PASSED

Once the gauss reading crosses the threshold, DETECTION starts, the pig state changes to PIG APPROACH and the pig approach screen is shown. The GAUSS reading shows the live gauss reading.

PIG PASSED is signalled when the flux reading has peaked and fallen by a defined drop as specified by the DETECTION CRITERIA, reference section 4.5.11 DETECTION METHOD. The larger the defined drop, the more likely that the pig has passed the unit. However, if the signaller is located close to the pig receiver, then a smaller drop should be considered as the pig's magnetic signal may not fully clear the signaller.

During DETECTION the display shows PIG nnn PASSED and the LEDs around the display will flash every 1 second and the relay and current loop outputs will be in the DETECTION state, the unit will keep logging until its internal buffer is full (or the CONTROL BUTTON is pressed), the event will then be logged.

If DETECTION starts and the pig does not pass the signaller, the signaller will timeout after 3 minutes and 20 seconds the signaller and will return to LISTENING (no DETECTION delay), the data will be logged but no event will be signalled. In this situation, the pig has been detected but is likely to have stopped before the signaller. If the pig then moves and passes the signaller (providing the gauss value exceed the THRESHOLD was far enough away to cause a peak – otherwise the signaller will timeout again and log the data), a PIG PASSED event is likely to be triggered. If the unit is in LP MODE, the screen will stay on until DETECTION completes or the unit times out and reverts to LISTENING where normal LP mode will resume.

4.4.2. PIG DETECTION ONLY

Once the gauss reading crosses the threshold, DETECTION starts, the pig state changes to PIG APPROACH and the pig approach screen is shown. The GAUSS reading shows the live gauss

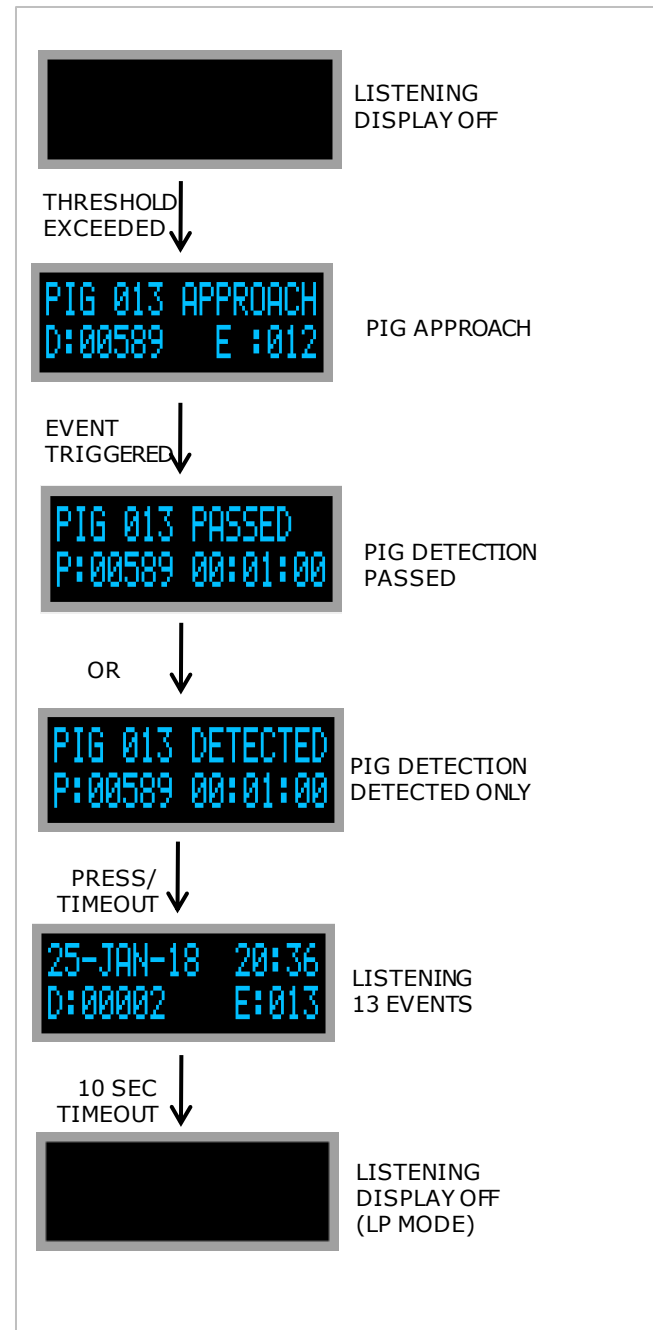

gauss reading shows the live gauss

DETECTION event is signalled when the flux reading has peaked and the buffer (at current fill rate) is filled.

During DETECTION display shows PIG nnn DETECTED and the LEDs around the display will flash every 1 second and the relay and current loop outputs will be in the DETECTION state.

The unit will remain in this state for the length of time defined by the DETECTION delay. A countdown timer representing the DETECTION delay will be shown at the bottom of the screen along with the peak gauss recorded. When the DETECTION delay reaches 00:00:00 the unit will return to LISTENING.

If DETECTION starts and there is no peak (i.e. pig inches closer but does not stop or pass) within 3 minute and 20 seconds the signaller will signal the pig DETECTION. If after the DETECTION period completes, the pig is still close and still moving (or moves away) such that the THRESHOLD is again crossed, a second DETECTION will occur.

4.4.3. DETECTION DELAY

The DETECTION delay controls how long the unit will signal an event for. Usually it will be configured to give the magnetic pig enough time to get out of range of the sensor after it has been detected to avoid re-trigger. When dealing with pig trains, the expected pig speed and separation should be used to configure a suitable value for the DETECTION delay such that the unit will not detect the same pig twice but will enter LISTENING mode in time to detect the next pig.

The unit can log up to 100 events with date, time, and the peak DIFFERENCE flux reading. Once 100 events have been logged the screen opposite will be displayed, indicating that the logger memory is full. Subsequent events will be signalled but no data will be logged (unless an SD card is installed, where the EVENT will be logged to the SD card).



The DETECTION delay can be set to any value between 00:00:00 and 98:59:59 (in HH:MM:SS format) using the CONTROL BUTTON or via the serial link. There are 2x special values which can be used:

DEBUG MODE – If the DETECTION delay is set to 00:00:00 then the unit works in DEBUG mode. If a reading greater than the THRESHOLD value is detected in DEBUG mode then the LEDs will flash every 5 seconds to indicate that the THRESHOLD has been crossed, but no EVENT will be logged, and the unit will not start a DETECTION delay. This can be very useful for determining the magnetic signature of a pig when used in combination with the CONFIGURATION SOFTWARE.

LATCHED DETECTION – If the DETECTION delay HH (hours) field is set to 99 then when an EVENT occurs the unit will LATCH in DETECTION mode showing the EVENT information and flashing the LEDs every 1 second. To begin LISTENING again the CONTROL BUTTON must be pressed or any serial command received. The EVENT data will be logged once the event buffer has been filled.

4.5. SINGLE BUTTON MENU INTERFACE

While LISTENING, the control button can be pressed for > 2 seconds to enter the menu interface. While in the menu interface, the unit will ignore all magnetic disturbances including PIG passages. From the menus the user can configure several parameters which are discussed in this section.

The menu interface is navigated using the control button. A momentary button press (< 1 second) cycles through the menu items and a long button press (> 3 seconds) selects the current menu item. If the control button is not pressed for 30 seconds, or if the user selects the EXIT MENU option the unit will return to LISTENING mode.

LONG CONTROL
BUTTON PRESS
> 3 SECONDS

SHORT CONTROL
BUTTON PRESS
< 1 SECOND

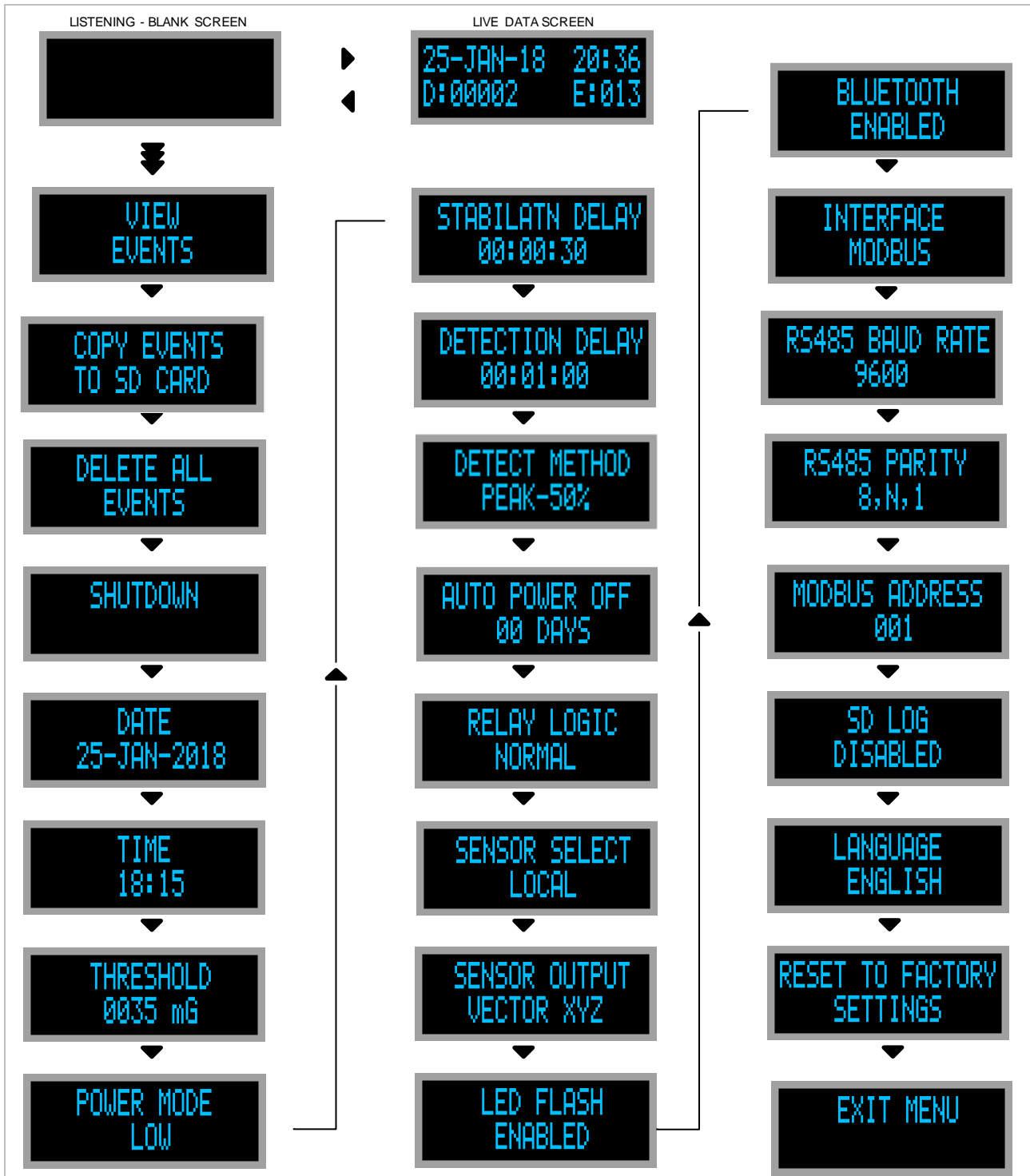

When an editable menu item has been selected a '>' will appear in the bottom left corner of the display to indicate that the selected menu item is now in edit mode and the button may be released. The cursor will blink to indicate the field currently being edited.

In edit mode a momentary button press (< 1 second) cycles through the possible options. (See POWER MODE example)

For menu options such as date and time where there are numeric fields to edit, press and hold to advance the cursor to the next digit. Once the last digit has been reached the cursor will loop back to the first. (See MODBUS ADDRESS example)

Once the value has been configured as required a long button press (> 3 seconds) is required to save the new value to memory. Once the button has been pressed long enough to save the value a '*' will be displayed in the bottom left corner of the screen to indicate that the button may now be released. The display will now return to the main menu.

When a menu item that performs an action such as view events is selected a '*' will be displayed in the bottom left corner of the display to indicate that the item has been selected and the desired action will be performed once the button has been released.

Should a menu item be selected for editing inadvertently then in order to prevent making an undesired change, do not press the button for ~30 seconds. This will cause the menu system to time out and the item value will not have been modified.

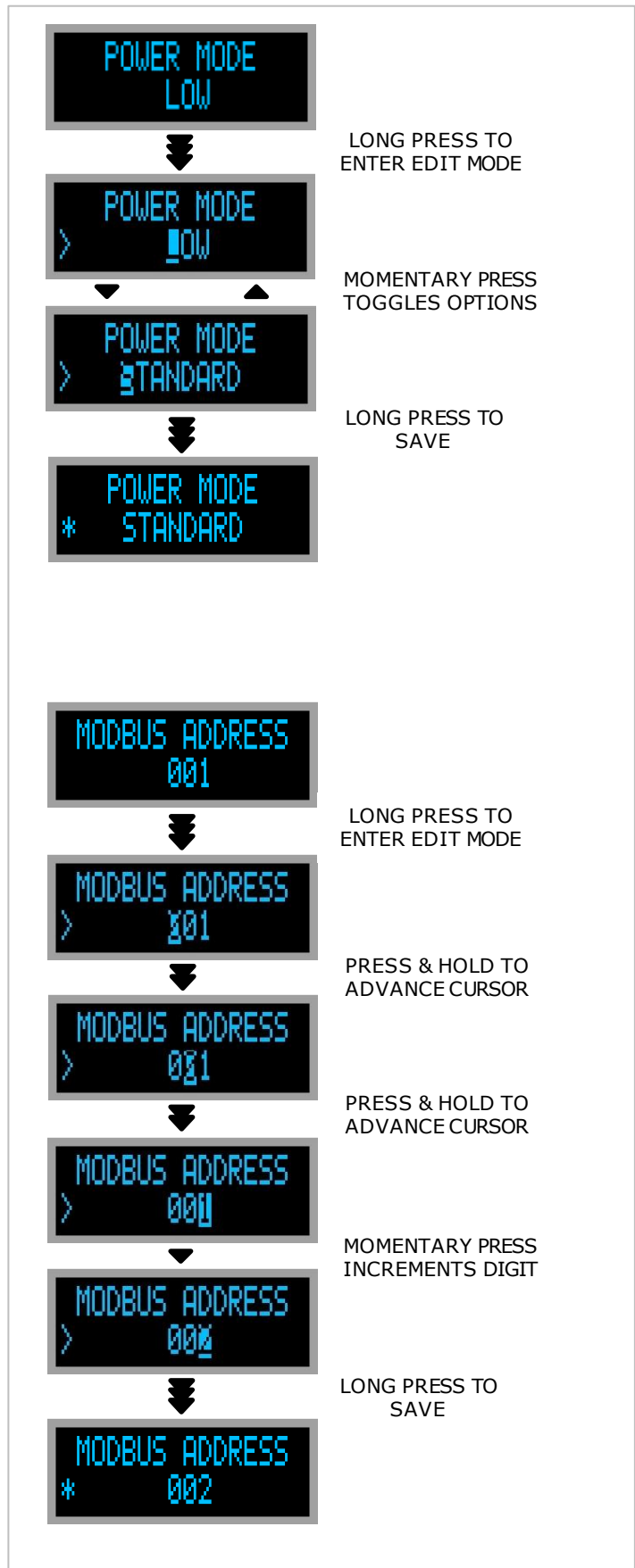

4.5.1. VIEW EVENTS

Selecting this item will allow the user to cycle through all logged EVENTS from newest to oldest. The peak DIFFERENCE flux reading, EVENT number, and EVENT date and time are shown. Pressing the CONTROL BUTTON momentarily will cycle to the next event. If the control button is not pressed for 30 seconds, or if the user cycles beyond the last recorded event the unit will return to LISTENING mode.

4.5.2. COPY EVENTS TO SD CARD

Selecting this item will copy ALL events (including erased events) to the SD card if present. If the SD card is not present, an "SD CARD NOT INSTALLED" error will be displayed. If the EVENT memory has not been previously written an "EVENT XXX SKIPPED" will be displayed. For each event successfully written to SD card as "EVENT XXX SUCCESSFUL" will be shown. If the event already exists on the SD card; with same detection time/date, it will be overwritten. The process can be stopped by pressing the CONTROL BUTTON.



Each event written will be in Comma Separated Values (.csv) format which can be read by most spreadsheet applications. The filename format of "YYMMDD HHMMSS EVENT XXX LOG.csv", where YYMMDD is the date, HHMMSS is the time and XXX is the event number.



Each log file will consist of



Event No:	XXX
Threshold Time:	DD/MM/YY HH:MM:SS
Detection Time:	DD/MM/YY HH:MM:SS
Peak Difference:	3699mG
Peak Raw	4216mG
Filter:	0517mG
Log interval	0.1 Seconds
Detection index	125
Status:	0

Event Data
XXXX, XXXX XXXX
End of Event Data

The log interval is the time span between each data value.
Detection index is the index of the data value where the detection criteria was met.

4.5.3. DELETE ALL EVENTS

Selecting this item will delete all logged EVENT data. A screen will be displayed saying "PRESS TO ERASE ALL EVENTS". To erase all events, press the CONTROL BUTTON before the COUNTDOWN INDICATOR reaches 0. To cancel the erase simply allow the COUNTDOWN INDICATOR to reach 0 without pressing the CONTROL BUTTON.

4.5.4. SHUTDOWN

Selecting this item switches off the unit. The unit will remember all settings (such as the DELAYS and THRESHOLD) until next time the unit is switched on.

4.5.5. DATE

Selecting this item allows the date to be adjusted. Ensure that a valid date is entered in DD/MMM/YY format. Refer to Section 4.12 RTC BACKUP.

4.5.6. TIME

Selecting this item allows the time to be adjusted. Ensure that a valid time is entered in 24hour, HH:MM format. Refer to Section 4.12 RTC BACKUP.

4.5.7. THRESHOLD

 CAUTION: Adjusting this parameter without first consulting Online Electronics Ltd may cause the unit to miss pig passages or give false detections.

Selecting this item allows the THRESHOLD level to be configured to control the sensitivity of the unit. The standard THRESHOLD value is 35mG. Reducing the THRESHOLD value increases the sensitivity. The THRESHOLD can be configured to any value between 5mG and 9999mG.

4.5.8. POWER MODE

Selecting this item allows the power mode to be configured. In STANDARD POWER MODE the display will be ON all of the time. The display draws significant power from the batteries which will reduce the battery life of the unit. In LOW POWER MODE the display will turn OFF after 10 seconds to preserve the battery life. The detection routines are identical in each mode.

4.5.9. STABILISATION DELAY

Selecting this item allows the STABILISATION delay to be configured. It is possible to configure any value between 00:00:00 and 99:59:59 in HH:MM:SS format. Refer to Section 4.2 STABILISATION for further information on the STABILISATION delay functionality.

4.5.10. DETECTION DELAY

Selecting this item allows the DETECTION delay to be configured. It is possible to configure any value between 00:00:00 and 99:59:59 in HH:MM:SS format. See section 0 DETECTION for further information on the DETECTION delay functionality.

4.5.11. DETECTION METHOD

Selecting this item allows the detection method to be configured. The options available are:

- PEAK – 50%
- PEAK – 25%
- PEAK – 10%
- PEAK – 05%
- DETECTION ONLY

PEAK – xx% determine the PIG PASSED detection criteria, reference 4.4.1 PIG PASSED, and the DETECTION ONLY selects the pig detection only detection criteria, reference section 4.4.2 PIG DETECTION ONLY.

4.5.12. AUTO POWER OFF

Selecting this item allows the AUTO POWER OFF function to be configured. It is possible to configure any number of days from 01 to 28.

The AUTO POWER OFF timer will be ENABLED immediately once any non-zero value is set.

While ENABLED, each time the unit is powered ON the AUTO POWER OFF timer will restart and the unit will automatically shut down after the configured number of days has elapsed.

To DISABLE the AUTO POWER OFF feature the number of days must be set to 00.

The AUTO POWER OFF feature will only operate when the unit is being powered from the internal batteries. If the unit has an active external power connection, then it will be automatically powered on at all times and this feature should be disabled.

4.5.13. RELAY LOGIC

Selecting this item allows the RELAY LOGIC to be configured.

If RELAY LOGIC is configured as NORMAL then while in the LISTENING state, the Normally Closed contacts of the relays will be connected to their respective Common contacts and the Normally Open contacts will be open. While in the DETECTION state, the Normally Closed contacts of the relays will be open and the Normally Open contacts will be connected to their respective Common contacts.

If RELAY LOGIC is configured as INVERTED then while in the LISTENING state, the Normally Closed contacts of the relays will be open and the Normally Open contacts will be connected to their respective Common contacts. While in the DETECTION state, the Normally Closed contacts of the relays will be connected to their respective Common contacts and the Normally Open contacts will be open.

4.5.14. SENSOR SELECT

Selecting this item allows the active magnetic sensor to be selected.

If LOCAL is selected, then the INTERNAL magnetic sensor will be active.

If REMOTE is selected, then the REMOTE magnetic sensor will be active.

4.5.15. SENSOR OUTPUT

Selecting this item allows the user to configure which components of the magnetic field are used by the unit to detect pig passages. There are currently four possible selections.

VECTOR XYZ – Full 3D magnetic field strength will be used.

X-AXIS – Only the x component will be used.

Y-AXIS – Only the y component will be used.

Z-AXIS – Only the z component will be used.

4.5.16. LED FLASH

Selecting this item allows the HIGH BRIGHTNESS LED INDICATORS fitted to the front of unit to be ENABLED or DISABLED.

4.5.17. BLUETOOTH

Selecting this item allows the Bluetooth module to be ENABLED or DISABLED. The Bluetooth module should be disabled when not required as the module draws significant power from the batteries which will reduce the battery life of the unit. Refer to Section 5 BLUETOOTH INTEGRATION

4.5.18. INTERFACE

Selecting this item configures the interface type. Either MODBUS, using the RS485 interface, or CURRENT LOOP signaling. When current loop is enabled pig passage is signaled by drawing more current on the power supply/current loop connection.

4.5.19. RS485 BAUD RATE

Selecting this item configures the BAUD rate for the serial interface. Either 19200 BAUD (required by MODBUS protocol) or 9600 BAUD can be selected. The word size is fixed at 8 bits with one stop bit. In total 11 bits are transmitted per character, START + 8 BIT DATA + PARITY + STOP BIT.

4.5.20. RS485 PARITY

Selecting this item configures the type parity check for the serial interface. Either EVEN PARITY (required by MODBUS protocol) or NO PARITY can be selected. In total 11 bits are transmitted per character, START + 8 BIT DATA + PARITY + STOP BIT.

4.5.21. MODBUS ADDRESS

Selecting this item configures the MODBUS slave address for the unit. Valid addresses are from 1 to 247.

4.5.22. SD LOG

Selecting this item allows the SD Logging feature to be ENABLED or DISABLED. This feature can be used to log magnetic flux readings from the sensor to an SD card (if fitted). Timestamped data is logged every 200mS using the Comma Separated Value format (.csv). Logging (when enabled) occurred while the signaller is powered, and SD card fitted with suitable capacity.

Data is recorded at approximately 3.5 seconds per kByte.

A 16Gbyte SD card would last for approximately 1.5 years depending on other data logged, reference 4.7 EVENT LOGGING AND SD Card.

4.5.23. LANGUAGE

Selecting this item allows the menu interface language to be selected.

4.5.24. RESET TO FACTORY SETTINGS

Selecting this item will restore the unit settings back to factory defaults. Performing this action will also delete all stored events.

4.5.25. EXIT MENU

Selecting this item will EXIT the menu interface and the unit will resume LISTENING.

4.6. MODBUS RTU RS485 INTERFACE

Communication to the 4003, via the RS485 interface, makes use of MODBUS protocol as defined in MODBUS OVER SERIAL LINE V1.02 published by the MODBUS organisation. The communication parameters adhere to this standard using the default RTU transmission mode. Communication parameters can be set up via the Menu System, Bluetooth application or MODBUS itself. All the parameters in the 4003 can be accessed via the MODBUS interface. MODBUS is also used over Bluetooth via a VCP connection which requires additional software.

The 4003 implements an exclusive block structure where each type of block has its own unique addresses. The base address for each type will remain constant although the content and number of each type of registers maybe updated but a table will exist in the manual detailing the register map applicable to the version of software for the 4003.

TYPE	START ADDRESS	FUNCTION CODES
COILS	10000	1,5
HOLDING REGISTERS	40000	3,6,16
INPUT REGISTERS	30000	4

The 4003 contains two processing units. The Main Processor performs the majority of the operational functions of the unit. The Communications Processor handles current loop signalling and MODBUS communications. The two units are electrically isolated from each other so that the communication interface can be isolated from the housing earth connection. The electrical ground connection for the Main Processor is connected to the housing earth due to the use of Zener Barrier type circuits inside the 4003 as required by hazardous area certification.

When MODBUS registers are updated the new values need to be transferred from the Communications Processor to the Main Processor so there is a slight delay to enable this to be performed. The Communications Processor keeps a copy of all registers which are updated by the Main Processor. Again, there may be a slight delay in this update.

4.6.1. MODBUS REGISTER MAP

Care should be taken when remotely controlling/configuring the 4003 via the MODBUS interface as values set intentionally, or unintentionally, will immediately affect the operation of the 4003. E.g. enabling relay inversion although a useful test will cause the relays to changeover and signal an indicate an event when no event is active.

In general:

Setting a coil activates the function detailed.

Reading a coil, whose contents are set, indicates STATUS active.

COILS		
REGISTER	STATUS/FUNCTION	DESCRIPTION
10000	Pig Detected Indication	Reference section 4.4
10001	Delete All Events	Reference section 4.5.2
10002	Enable Low Power Mode	Low power enabled when set
10003	Invert Relay Polarity	Refer to Section 4.5.13

RELAY LOGIC		
10004	Enable Remote Sensor	Remote sensor selected when set
10005	Enable SD Card Logging	
10006	Enable LED Flash	Refer to Section 4.5.16 LED FLASH
10007	Enable Bluetooth	
10010	Pig Approach Indication	Reference section 4.4

INPUT REGISTERS		
30000	Serial Number	Serial number of unit
30001	DOMyy	Year of manufacture
30002	DOMmm	Month of manufacture
30003	FWRevMajor	Software Revision Number
30004	FWRevMinor	Software Revision Number
30005	Number of events	Current number of events
30006	Event Date DD	Selected event date day
30007	Event Date MM	Selected event date month
30008	Event Date YY	Selected event date year
30009	Event Time HH	Selected event time hour
30010	Event Time MM	Selected event time minute
30011	Event Peak Value	Selected event peak magnetic flux
30012	Difference	Current relative flux
30013	Magnitude	Current flux magnitude
30014	xAxis	Current flux in x direction
30015	yAxis	Current flux in y direction
30016	zAxis	Current flux in z direction
30017	Battery Voltage	Current battery voltage if fitted

HOLDING REGISTERS		
40000	Language	Refer to Section 4.5.23 LANGUAGE
40001	APO Days	Refer to Section 4.5.12 AUTO POWER OFF
40002	Stabilisation HH	Refer to Section 4.5.9 STABILISATION DELAY
40003	Stabilisation Delay MM	
40004	Stabilisation Delay SS	
40005	Detect Delay HH	Refer to Section 4.5.10 DETECTION DELAY
40006	Detect Delay MM	
40007	Detect Delay SS	
40008	System Date DD	Current day
40009	System Date MM	Current month
40010	System Date YY	Current year
40011	System Time HH	Current hour
40012	System Time MM	Current minute
40013	Event Requested	Event number to view over MODBUS
40014	MODBUS Slave Address	MODBUS slave address
40015	RS485 Baud Rate	If set = 19200 BAUD, if clear = 9600 BAUD
40016	RS485 Parity	If set = EVEN parity, if clear = NO PARITY
40017	Threshold	Refer to Section 4.5.7 THRESHOLD
40018	Sensor Output	
40020	Detection Type	0 = Peak Value - 50% 1 = Peak Value - 25% 2 = Peak Value - 10% 3 = Peak Value - 5%, 4 = Detection Only Reference section 4.5.11

4.7. EVENT LOGGING AND SD CARD

4.7.1. EVENT LOGGING

The signaller contains EEPROM memory capable of recording 127 elements of EVENT data as well as other data including time, date and peak. These logged EVENTS occur on each DETECTION (and non-detections EVENTS in PIG PASSED detection mode) and are retained until erased.

This EVENT data can be copied to SD card via the menu system providing an SD card is fitted; reference 4.5.2 COPY EVENTS TO SD CARD.

4.7.2. SD CARD

The micro SD Card (if installed) can be used to record 3 types of data.

Log Data:

While enabled, the sensor data will be logged to SD card reference 4.5.22 SD LOG at a rate of 1 entry every 200mS. The data log file will be automatically created on power up and closed on shutdown.

The filename format is "YYMMDD HHMMSS 4003 LOG.csv".

The date and time is the point the file was created

Detection Log:

A DETECTION log file is created with each EVENT occurrence. The event file is similar to the EVENT LOG. The detection log is created if the SD Card is present even if the Log Data is not enabled.

Filename format is "YYMMDD HHMMSS 4003 DETECTION LOG.csv"

The date and time point when the detection criteria was met.

Event Log:

An EVENT log file is created when the EVENTS stored in EEPROM are copied to the SD Card, reference 4.5.2 COPY EVENTS TO SD CARD.

Filename format is YYMMDD HHMMSS 4003 EVENT nnn LOG.csv".

Where nnn is the event number.

The date and time point when the detection criteria was met.

4.8. MOUNTING

Normally the unit is used to confirm whether or not a pig has passed a known point of interest in a pipeline such as a bend or valve. Ideally the unit should be mounted approximately 5m after the point of interest. If the unit is mounted too close then it may detect the pig before the pig has passed safely through the point of interest.

If it is not possible to mount the signaller 5m after the point of interest then a test run would be advantageous to determine the typical strength of magnetic signal coming from the pig and then the detection range can be reduced accordingly by increasing the THRESHOLD value referring to Section 4.5.7 THRESHOLD of this manual.

The unit is supplied with a mounting plate. The unit can be mounted with a ratchet strap or steel band. For either method follow the procedure below, using the manufacturer's instructions which are provided with this equipment:

1. The Special Conditions for Safe Use detailed in Section 9 SAFETY INSTRUCTIONS of this manual must be observed at all times.
2. Ensure the mounting plate is securely fitted to the housing.
3. Temporarily place the unit at the chosen location to ensure that the unit sits in place without rocking.
4. Loop the band through the slots provided as shown and then gradually tighten the band until the unit is held firmly. Do not use excessive force.
5. An external earthing connector suitable for 4mm² (12AWG) wire is available on the enclosure body should equipotential bonding or earthing be required.

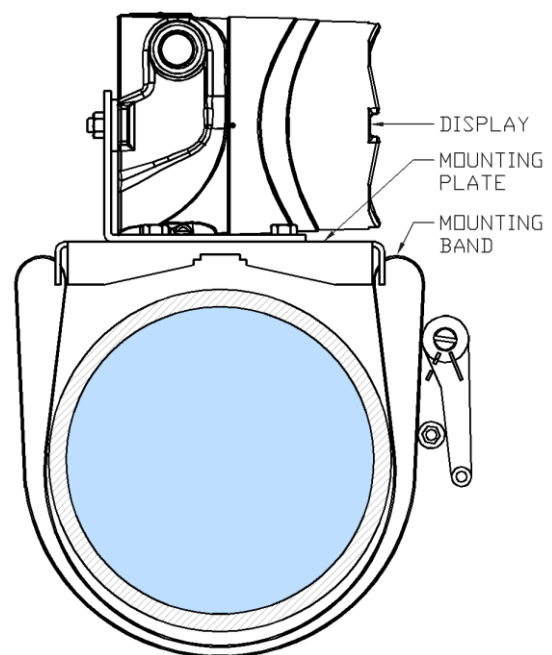

4.8.1. REMOTE SENSOR MOUNTING

If fitted, the remote sensor is mounted using the supplied mounting plate and a ratchet strap or steel band similar to the main housing

Loop the band through the slots provided on the remote sensor mounting plate as shown and then gradually tighten the band until the sensor is held firmly. Do not use excessive force.

If the pipeline surface temperature is expected to exceed +85°C then a thermally insulating pad will be supplied fitted to the remote sensor. In this case the sensor must be fitted on the lower half of the pipeline as shown to minimise convection heating.

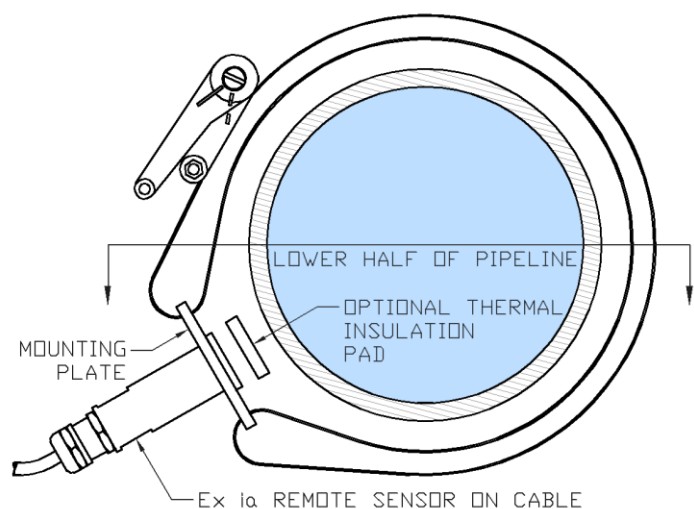

4.9. BATTERY REPLACEMENT

The unit will shut down when the battery voltage reaches 4.0V. To replace the batteries, follow the steps below:

The Special Conditions for Safe Use detailed in Section 9 SAFETY INSTRUCTIONS of this manual must be observed always. Only the cell type stated should be installed in the unit.

Using an Allen key loosen the locking set screw located on the perimeter of the ENDCAP.

Carefully unscrew the ENDCAP while being prepared to take the weight when it disengages.

Using a 4mm AF Allen key loosen the M5 cap screw located in the centre of the faceplate then carefully lift out the INTERNAL ASSEMBLY.

Replace all batteries confirming that their polarity matches that indicated by the markings within the battery compartment. The negative end of each battery should be in contact with a spring as shown opposite.

REPLACE ALL BATTERIES AT THE SAME TIME. NEVER USE A MIX OF NEW AND USED BATTERIES. ENSURE THAT THE CORRECT BATTERY TYPE IS USED AND ARE ALL OF THE SAME TYPE. ALWAYS OBSERVE CORRECT BATTERY POLARITY.

Replace the INTERNAL ASSEMBLY ensuring that the orientation is correct. Note that a dowel pin is provided to assist with alignment of the assembly, however care should be taken to avoid damaging the board to board connector when mating.

Tighten the M5 cap screw in the centre of the faceplate. Do not over tighten, very little torque is required.

Replace the ENDCAP and gently hand tighten. Do not use tools or over tighten otherwise the endcap will be difficult to remove.

Gently tighten the Endcap locking screw. Do not over tighten, very little torque is required to lock the endcap in place.

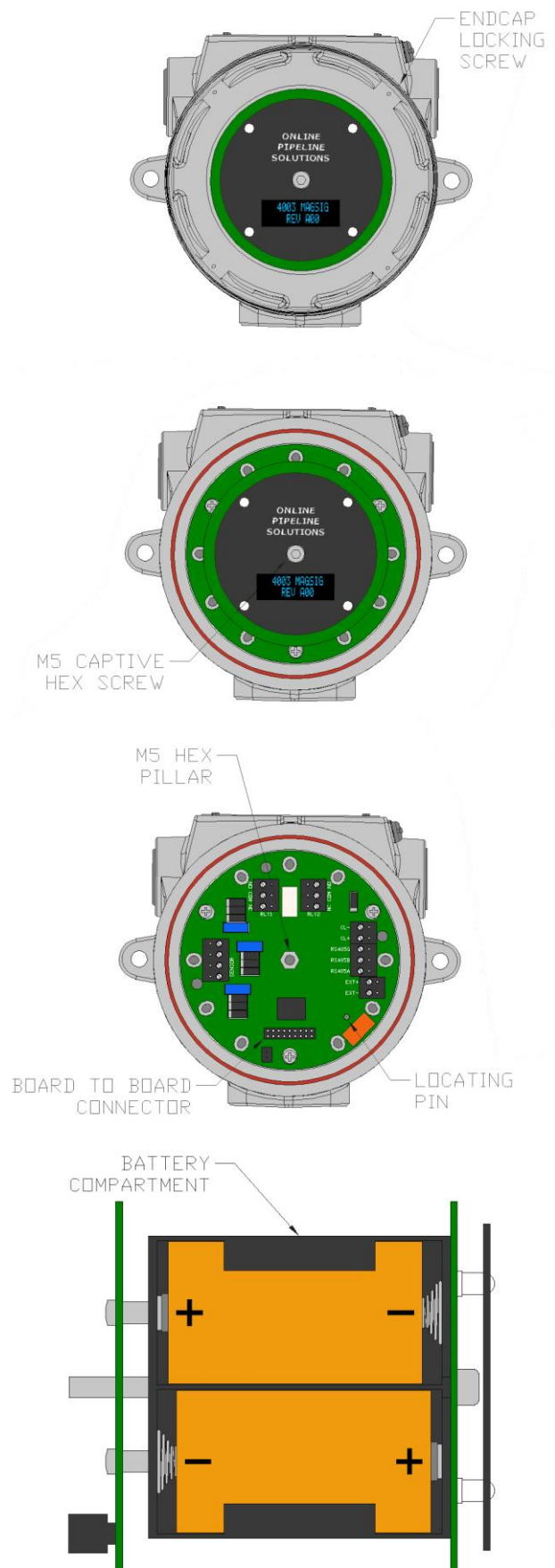

4.10. EXTERNAL CONNECTIONS

To access external connections, follow the steps below:

1. The Special Conditions for Safe Use detailed in Section 9 SAFETY INSTRUCTIONS of this manual must be observed at all times.
2. Remove the ENDCAP and INTERNAL ASSEMBLY as described in Section 4.9 BATTERY REPLACEMENT of this manual to reveal the external connections as shown.

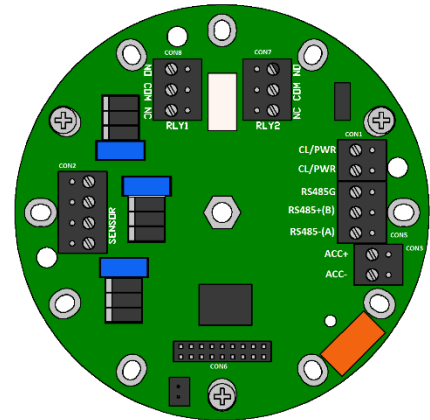

All connections are made using 5.0mm pitch pluggable terminal blocks which can accept up to 2.5mm² (12AWG) wire size. All connections must be made using suitable crimp ferrules. Connections are clearly labelled on the PCB and have the following functions:

NC	- Normally Closed contact of relay pole 1 and 2
COM	- Common contact of relay pole 1 and 2
NO	- Normally Open contact of relay pole 1 and 2
CL/PWR	- External 24VDC supply or Current Loop input (non-polarised)
CL/PWR	- External 24VDC supply or Current Loop input (non-polarised)
RS485G	- RS485 GND
RS485+(B)	- RS485 DATA + (B)
RS485-(A)	- RS485 DATA - (A)
ACC+	- Accessory power supply positive
ACC-	- Accessory power supply negative
SENSOR	- Remote Sensor connection

4.10.1. RELAY OUTPUT

⚠ WARNING: The Special Conditions for Safe Use detailed in section 9 SAFETY INSTRUCTIONS of this manual must be observed at all times.

⚠ WARNING: If intrinsically safe equipment is attached to the relay then both relay connectors (CON7 & 8) must have covers fitted and only intrinsically safe connections may be made to any relay contacts. See Special Conditions for Safe Use detailed in section 9 SAFETY INSTRUCTIONS.

The relay output is DPDT (Double Pole Double Throw) meaning that there are two separate sets of contacts (NC / COM / NO for RLY1 & RLY2) which may be connected to two separate external circuits.

While in the LISTENING state (see section 4.3 LISTENING), the Normally Closed contacts of the relays will be connected to their respective Common contacts and the Normally Open contacts will be open.

While in the DETECTION state (see section 4.4 DETECTION MODE) DETECTION, the Normally Closed contacts of the relays will be open and the Normally Open contacts will be connected to their respective Common contacts.

4.10.2. CURRENT LOOP OUTPUT

The current loop connections are non-polarised. Ensure that +21.6VDC to +26.4VDC is maintained at the unit connections.

While in the LISTENING state (refer to Section 4.3 LISTENING), the unit will consume 16.0mA \pm 1.0mA.

While in the DETECTION state (refer to Section 4.4 DETECTION MODE), the unit will consume 20.0mA \pm 1.0mA.

4.11. INTERNAL HEATER

⚠ WARNING: REFER TO SECTION 9 SAFETY INSTRUCTIONS.

⚠ WARNING: DO NOT OPEN THE ENCLOSURE WHILST POWER IS APPLIED TO THE HEATER CIRCUIT.

⚠ WARNING: ALLOW AT LEAST 15 MINUTES FOR THE HEATER ELEMENT TO COOL IF IT HAS BEEN OR SUSPECTED TO HAVE BEEN IN OPERATION.

⚠ WARNING: HOT SURFACES MAY BE PRESENT WITHIN THE UNIT IF POWER HAS BEEN APPLIED TO THE HEATER SUPPLY TERMINALS.



The 4003 configured for external power also has an internal thermostatically controlled heater assembly. If power is applied to EXT+ & EXT- then the heater will activate whilst the temperature inside the unit is below -25°C (-13 °F).

A separate 2 pin terminal block (EXT+ & EXT-) is provided to connect external voltage to the heater. The heater has a maximum applied supply voltage of 26V although typically 24V should be applied.

The power dissipation (Pd) stated on the marking label can be taken as the power rating of the heater element. Reference should be made to Section 9 SAFETY INSTRUCTIONS for applicable ambient temperature limits for when power is applied to the heater.

The required current supply necessary to power the heater can be calculated from this power and the applied voltage $I = P/V$. Typically a <5W heater is fitted so current = $5/24 = 0.2A$. A supply capable of providing at least this current will be necessary to operate the heater correctly.

4.12. RTC BACKUP

The unit includes RTC backup to retain the date & time.

If the unit is turned off but the main batteries or the external power is left connected, then memory backup will retain these settings indefinitely.

If the unit is turned off and main batteries and external power are removed then memory backup will retain these settings for a minimum of 50 days.

If memory backup expires then the warning message shown opposite will be displayed when the units is next turned on. The date and time must be set as per Section 4.5.5 DATE and Section 4.5.6 TIME.



4.13. RECOMMENDED MAGNET ARRANGEMENT

Refer to the table below for recommended quantities and type of magnets required for pipeline diameter and wall thickness. The magnets should be spaced equally around the pig body with all magnets oriented with the same poles facing outwards e.g. all north poles facing outwards (as shown) or all south poles facing outwards. It is critical that the magnets are not oriented with a mixture of north and south poles facing outwards as this may result in 'dead-spots' in the magnetic field around the pig. Magnets may be fixed to the pig body, embedded in the pig discs or embedded in foam pigs. The cost of quality magnets is insignificant compared to the potential cost of a lost pig which is more likely if unsuitable, cheaper magnets are used. Effective pig detection is dependent on several factors including:

PIPE WALL THICKNESS – The thinner the pipe wall, the stronger the magnetic signal.

PIPELINE MATERIAL – Different materials cause different attenuations to the magnetic signals. For example, 50mm of concrete will affect the signal considerably less than 50mm of mild steel.

DISTANCE BETWEEN MAGNET AND SENSOR – The closer the magnets are to the magnetic sensor, the stronger the magnetic signal.

NUMBER OF MAGNETS FITTED TO PIG – The more magnets which are placed around the pig, the more uniform and effective the overall magnetic field is.

STRENGTH OF MAGNETS – The stronger the magnets, the stronger the magnetic signal.

BACKGROUND MAGNETIC NOISE – The more magnetically quiet the surrounding area is, the more sensitive the signaller can be set without the risk of false triggers. Movement of magnetic objects close to the signaller should be avoided to prevent false triggers.

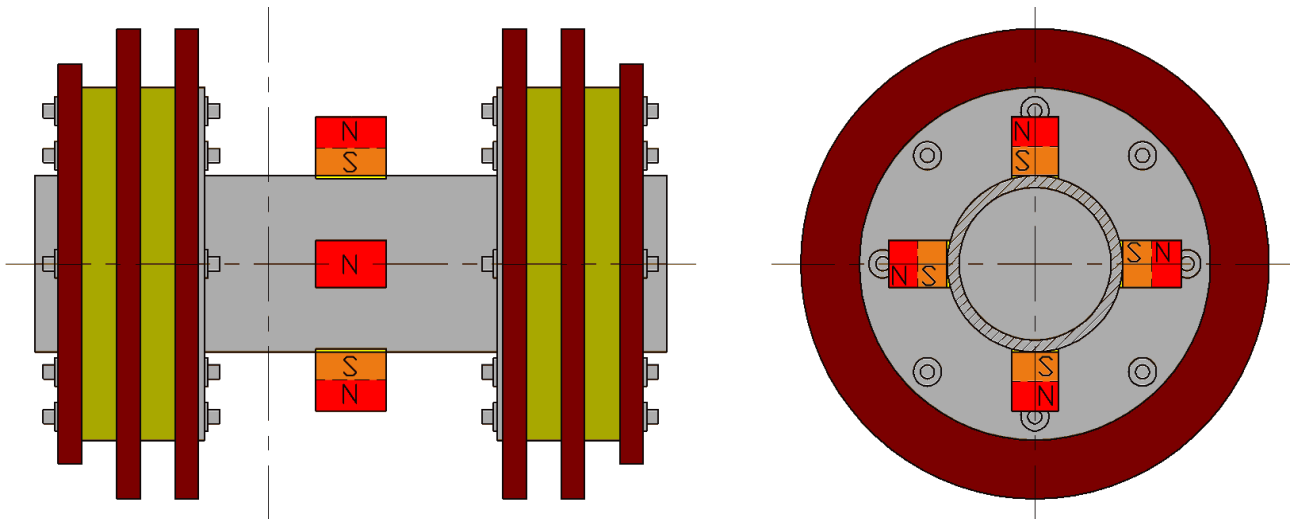

PIPELINE DIAMETER	PIPELINE WALL THICKNESS	MAGNET TYPE & DIMENSIONS	NUMBER OF MAGNETS EQUISPACED AROUND PIG
10"	10.2mm	NdFeB N35 ø20x20mm	8
10"	10.2mm	NdFeB N35 ø48x18mm	4
12"	11.3mm	NdFeB N35 ø20x20mm	8
12"	11.3mm	NdFeB N35 ø48x18mm	4
14"	12.1mm	NdFeB N35 ø20x20mm	8
14"	12.1mm	NdFeB N35 ø48x18mm	4
16"	13.2mm	NdFeB N35 ø20x20mm	8
16"	13.2mm	NdFeB N35 ø48x18mm	4

5. BLUETOOTH INTEGRATION

The 4003 Bluetooth Application is designed for operation on any Android Device with an Operating system of Lollipop or greater. The application is designed to address the Modbus registers and coils to allow data collection and programming changes to be performed in an easy familiar manner. In some cases, sliding switches allow conditions or features to be turned on or off, in other cases, numbers can be input via a scroll wheel on a tabular entry.

5.1. BLUETOOTH ENABLE

Refer to Section 4.5 SINGLE BUTTON MENU INTERFACE of this manual for information on how to utilise the pushbutton menu interface and Section 4.5.17 BLUETOOTH for information on turning the Bluetooth feature ON & OFF.

NOTE: The Bluetooth feature when turned on will draw significantly more power than when normally off. The feature is enabled when a blue flashing LED blinks in the top center of the display.

5.2. BLUETOOTH CONNECTION

When the blue light is flashing on the 4003 (approximately one flash every 2 seconds), enable the Online Icon for the 4003 Bluetooth communication feature on your device and stand within 3 to 4 feet of the front glass of the unit with your handheld pointing at the glass window. Tap "SCAN" it should make connection with the unit (the blue light will begin flashing 2 times with a 1 second time between groupings, this indicates a connection was achieved) and display will indicate STARTING. Once the device is connected, it will indicate "DISCONNECT" as your next choice and values will fill in the screen.

You may want to disable or extend your screen "sleep" time while interfacing with this unit, if you must keep tapping the screen or if the device goes to sleep, you may get abbreviated data on export.

ENSURE to disable the Bluetooth feature If using the Bluetooth feature on battery powered 4003s, disable the feature when you are finished as the feature draws significant power and will cause significant reduction in the lifespan of your batteries.

Refer to the graphic on the next page for how your device will look when connected to the 4003 unit via Bluetooth.



5.3. DEVICE DISPLAY INFORMATION

Referring to the graphic above, at the very top of the screen, BATTERY LEVEL, SIGNAL STRENGTH, CONNECTION STATUS and the ANDROID MENU will be displayed.

If you select the ANDROID MENU function, a window will open that indicate the following:

1. EXPORT and E-MAIL
 - Selecting this option will export the current readings in CSV format. If you ask the unit later to "view all", a listing of all the recorded events will also be displayed.
2. IMPORT
 - Allows the import of a CSV file with pre-loaded settings
3. HELP
 - Displays the current version of the Bluetooth Software
4. EXIT

5.3.1. DEVICE CHANGEABLE FIELDS

The following fields are user changeable:

1. System Date/Time – Tabular Entry
2. Language – Multiple Choice
3. Auto Power off – Tabular Entry
4. Stabilization Delay – Tabular Entry
5. Detect Delay – Tabular Entry
6. Low Power Mode – Sliding switch
7. Relay Polarity – Sliding switch
8. Remote Sensor – Sliding switch
9. SD Card Logging – Sliding Switch
10. LED Flash – Sliding Switch
11. Baud Rate – Tabular Entry
12. Parity – Tabular Entry
13. Slave ID – Tabular Entry
14. Threshold – Tabular Entry

5.3.2. INDICATION ONLY

The following fields are indication only:

1. Pig Detected – either red or green
2. Event Peak Value
3. Difference
4. Current Flux
5. Battery Volts

5.3.3. LOGGED DATA:

100 Event Log – you can address each logged event by using left or right arrow keys or "View All" can be selected in which case they will cycle through completely. The values will indicate date and time of the event as well as the logged Milligauss level. At the end of the cycle the units will display the full list which you can print screen or if you export at this point a complete list will export with other readings via CSV file or to an SD Card.

6. ROUTINE MAINTENANCE AND STORAGE

All Online Electronics Ltd products are designed to require minimum maintenance. The housing should be cleaned using fresh water and cleaning agents as necessary.

If the unit is to be placed in storage for a long period of time ensure the unit has been cleaned, turned OFF and main batteries removed. Refer to Section 9 SAFETY INSTRUCTIONS

7. DISPOSAL

Online Electronics Ltd (OEL) takes its responsibilities under the WEEE Regulations extremely seriously and has taken steps to be compliant in line with our corporate and social responsibilities. In the UK, OEL has joined a registered compliance scheme WeeeCare (registration number WEE/MP3538PZ/SCH).

Electrical and electronic equipment should never be disposed of with general waste but must be separately collected for the proper treatment and recovery.

The crossed-out bin symbol, placed on the product, reminds you of the need to dispose of it correctly at the end of its life.

When buying a new product, you will have the possibility to return, free of charge, another end of life product of equivalent type that has fulfilled the same functions as the supplied equipment. These items may be deposited at:

Online Electronics Ltd
Online House
Woodburn Road
Blackburn Business Park
Blackburn
Aberdeen
AB21 0PS
UK

Alternatively, to arrange a collection of any waste electrical equipment, obligated to OEL please telephone WeeeCare on 0844 800 2004.

8. WARRANTY

Online products are guaranteed for one year from the date of purchase. Goods should be returned transportation prepaid to Online Electronics Limited.

There is no charge for parts or labour should any product require repair due to a manufacturing deficiency during the guarantee period.

In the event of a manufacturing deficiency the inward transportation costs will be repaid to the client.

9. SAFETY INSTRUCTIONS

SPECIAL CONDITIONS FOR SAFE USE:

1. Do not open when an explosive gas atmosphere may be present.
2. Potential electrostatic charging hazard. The equipment should not be mounted in areas where it could be subjected to highly efficient charging mechanisms, such as fast moving dust or particle filled air, and shall only be cleaned with an anti-static or damp cloth.
3. Transducer, cable and electronics shall only be used as a complete assembly.
4. The equipment contains a shunt Zener diode interface which requires connection to a suitable earth in accordance with IEC/EN60079-14.
5. Internal and external threaded holes are provided for earthing and equipotential bonding. Protective earthing conductors employed shall be greater or equal to the size of the phase conductors, equipotential conductors shall have a minimum cross-sectional area of 4mm². The end user shall ensure conductors cannot be readily loosened or twisted. Light metals shall not be used unless special precautions are taken to guard against corrosion.
6. External power supply shall not exceed 30VDC.
7. External power and signals shall only be supplied according to manufacturers' instructions using suitable cable and suitable Ex certified glands.
8. The sensor cable length shall not exceed 20 meters.
9. All wiring for external connections shall be made using suitable crimp ferrules to prevent accidental disconnection as per IEC60079-11:2011 Cl. 6.2.2.
10. When the relay is used for IS interface, all relay contacts shall only be connected to intrinsically circuits. Once the contacts are connected to any non-IS circuits they are no longer be acceptable for IS interface.
11. Terminal blocks used to connect to external intrinsic safe circuits must have an insulating partition cover fitted.
12. Wire used for intrinsic safe circuit connection must have a conductor size of at least 0.05mm and shall have insulation with a minimum thickness of 1mm. Additional suitable insulating sleeving may fitted to achieve this.
13. Unused entries shall be sealed using suitable Ex certified blanking elements.
14. The temperature at the cable entry point may exceed +70°C. Cables suitable for use at this temperature must be used.
15. Battery types.
 - 15a. Use only ALKALINE, 1.5V, 18Ah, 4 off D cells, rated for at least 250mA continuous current (DURACELL INDUSTRIAL ID1300 recommended).
 - 15b. Use only LITHIUM THIONYL CHLORIDE, 3.6V, 17Ah, 2 off D cells, rated for at least 250mA continuous current (SAFT LS33600 recommended). Configured at manufacture.
 - 15c. Use only RECHARGEABLE NiMH, 1.2V, 8.5Ah, 4 off D cells, rated for at least 250mA continuous current (ANSMANN MAXE D recommended) applicable to ATEX/IECEx certification only.

16. As part of the routine maintenance schedule, the condition of the window cement shall be periodically inspected for any degradation or dis-colouration of the cement that may compromise the explosion protection.
17. None of the flame paths present on the enclosure are intended to be repaired.
18. Ambient temperature rating depends on temperature class, internal power dissipation, remote sensor and application of the relay. Refer to the tables below.

Without intrinsic interface to relay

	Temperature Class		
Power Supply	T6	T5	T4
External supply (1W)	-50 °C to +73 °C (NOTE 1 +78 °C)	-50 °C to +85 °C (NOTE 1 93 °C)	-50 °C to +85 °C
External supply (5W)	-50 °C to +70 °C	-50 °C to +85 °C	-50 °C to +85 °C
External supply (10W)	-50 °C to +60 °C	-50 °C to +75 °C	-50 °C to +85 °C
Alkaline battery (DURACELL, LR20)	-20 °C to +50 °C	-20 °C to +50 °C	-20 °C to +50 °C
Lithium battery (SAFT, LS33600)	-40 °C to +73 °C	-40 °C to +80 °C	-40 °C to +80 °C
NiMH battery (ANSMANN, 8500)	-20 °C to +60 °C	-20 °C to +60 °C	-20 °C to +60 °C

With intrinsic interface to relay

	Temperature Class		
Power Supply	T6	T5	T4
External supply (1W)	-40 °C to +73 °C (NOTE 1 78 °C)	-40 °C to +82 °C	-40 °C to +82 °C
External supply (5W)	-40 °C to +70 °C	-40 °C to +72 °C	-40 °C to +72 °C
External supply (10W)	-40 °C to +59 °C	-40 °C to +59 °C	-40 °C to +59 °C
Alkaline battery* (DURACELL, LR20)	-20 °C to +50 °C	-20 °C to +50 °C	-20 °C to +50 °C
Lithium battery* (SAFT, LS33600)	-40 °C to +73 °C (NOTE 1 78 °C)	-40 °C to +80 °C	-40 °C to +80 °C
NiMH battery* (ANSMANN, 8500)	-20 °C to +60 °C	-20 °C to +60 °C	-20 °C to +60 °C

NOTE 1: When batteries are fitted as back-up power in an externally-powered unit the ambient temperature for the battery unit shall take precedence between the two ranges.

NOTE 2: * - When the sensor is placed inside of the flameproof enclosure.

When the unit is externally powered (no batteries fitted) the upper ambient temperature limit can be interpolated based on power dissipation.

DECLARATION OF CONFORMITY

This declaration of conformity is issued under the sole responsibility of the manufacturer:

Online Electronics Ltd
Online House
Blackburn Business Park
Woodburn Road
Blackburn
Aberdeen
AB21 0PS
UNITED KINGDOM

Object of declaration:

4003 Magnetic Pig Signaller

With the following markings with the sensor inside the unit:

 II 2(1) G Ex db [ia Ga] IIC T4...T6 Gb

With the following markings with the sensor outside of the unit:

 II 1/2 (1)G Ex db ia [ia Ga] IIC T4...T6 Ga/Gb

The object of the declaration described above is in conformity with the relevant Union harmonisation legislation:

ATEX: ATEX Directive 2014/34/EU
IECEX: IECEX System
EMC: EMC Directive 2014/30/EU

The following harmonised standards and technical specifications have been applied:

ATEX: EN 60079-0:2012+A11:2013
EN 60079-1:2014
EN 60079-11:2012

IECEX: IEC 60079-0:2011
IEC 60079-1:2014
IEC 60079-11:2011

EMC: EN 61000-6-4:2007+A1:2011
EN 61000-6-2:2005

As per the certificates below:

ATEX: Sira 18ATEX1244X

IECEX: SIR 18.0059X

EMC: Certificate 5024TC1 issued by York EMC Services Ltd.

The apparatus named above has been designed to comply with the relevant sections of the above referenced specifications and complies with all essential requirements of the Directives and Systems.